

# Guide rail brackets

## Guide rail bracket Part. 213

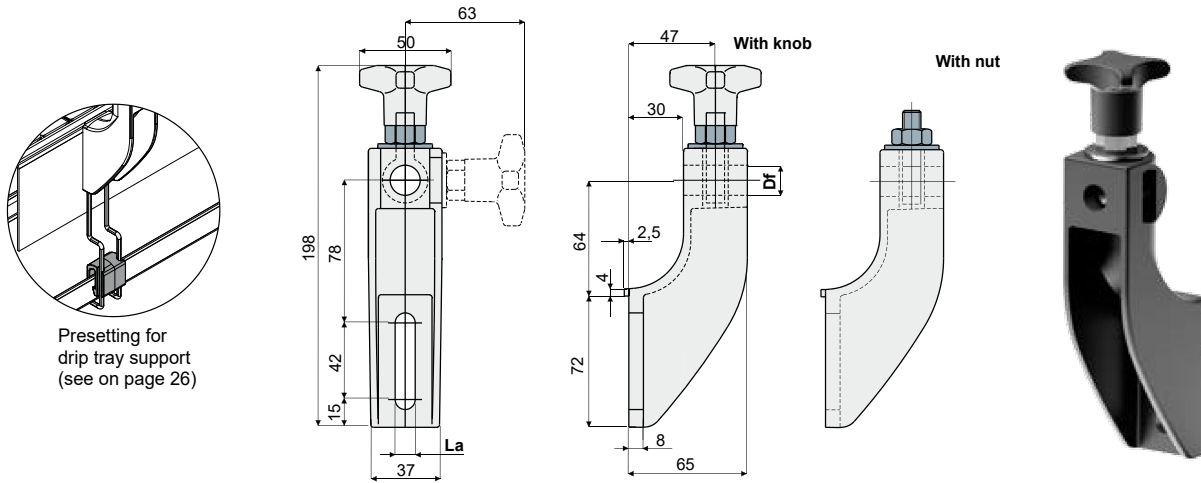

Df Bore for pin of (mm)	La (9 mm slot)	
	With knob Code	With nut Code
12	213 / 81176	213 / 82105
14	213 / 82102	213 / 82107
16	213 / 82104	213 / 82109

Df Bore for pin of (mm)	La (11 mm slot)	
	With knob Code	With nut Code
12	213 / 80652	213 / 80653
14	213 / 80654	213 / 80655
16	213 / 80656	213 / 80657

**MATERIALS:** Bracket and knob made of reinforced polyamide black colour; hexagonal insert made of nickel plated brass; eyebolt, nut and washer made of stainless steel AISI 304.

**FEATURES:** Max tightening torque 4 Kg-m.

**BOX QUANTITY:** 24 pieces.

**ON REQUEST:**

- Brackets: In reinforced polypropylene, other colours.
- Box Quantity: According to your request.

## Guide rail bracket Part. 214 (with adjustable head)

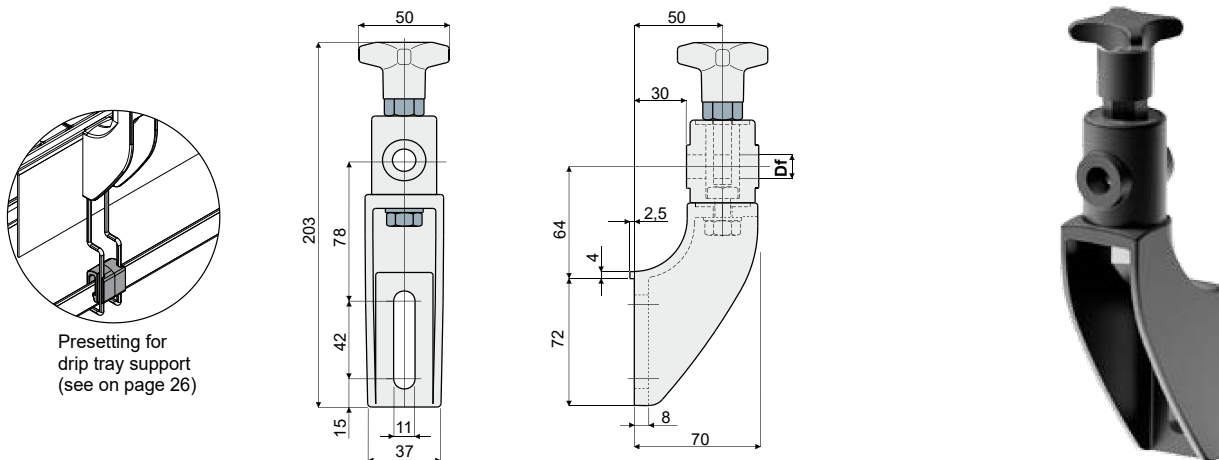

Df Bore for pin of (mm)	Code
12	214 / 80755
14	214 / 80756
16	214 / 80757

**MATERIALS:** Bracket and knob made of reinforced polyamide black colour; hexagonal insert made of nickel plated brass; eyebolt, nut and washer made of stainless steel AISI 304.

**FEATURES:** Max tightening torque 4 Kg-m.

**BOX QUANTITY:** 24 pieces.

**ON REQUEST:**

- Brackets: In reinforced polypropylene, other colours.
- Box Quantity: According to your request.

# Guide rail brackets

## Part. 215 Guide rail bracket (with adjustable head)

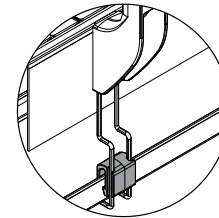
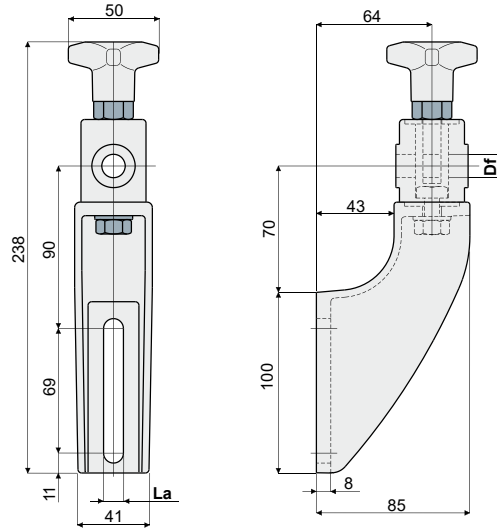

Presetting for drip tray support (see on page 26)

Df Bore for pin of (mm)	La (9 mm slot) Code	La (11 mm slot) Code
12	215 / 82106	215 / 80658
14	215 / 82108	215 / 80659
16	215 / 82110	215 / 80660

**MATERIALS:** Bracket and knob made of reinforced polyamide black colour; hexagonal insert made of nickel plated brass; eyebolt, nut and washer made of stainless steel AISI 304.

**FEATURES:** Max tightening torque 4 Kg-m.

**BOX QUANTITY:** 24 pieces.

**ON REQUEST:**

- Brackets: In reinforced polypropylene, other colours.
- Box Quantity: According to your request.

## Part. 243 Guide rail bracket (reinforced type with adjustable head)

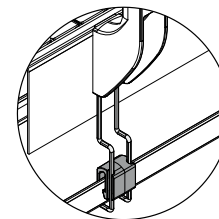
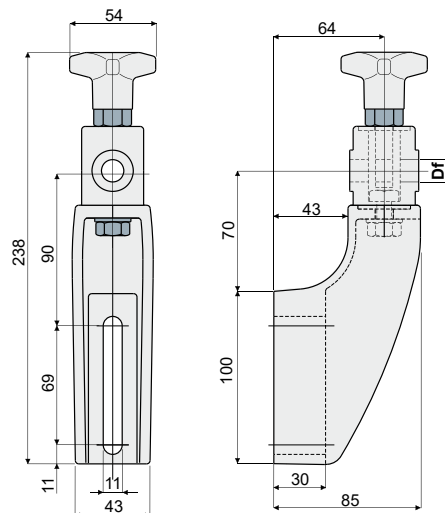

Presetting for drip tray support (see on page 26)

Df Bore for pin of (mm)	Code
12	243 / 81003
14	243 / 81004
16	243 / 81005

**MATERIALS:** Bracket and knob made of reinforced polyamide black colour; hexagonal insert made of nickel plated brass; eyebolt, screw, nut and washer made of stainless steel AISI 304.

**FEATURES:** To be used for heavy applications, suitable in conveyors with more ways, both in accumulation and curve. Max tightening torque 4 Kg-m.

**BOX QUANTITY:** 24 pieces.

**ON REQUEST:**

- Brackets: In reinforced polypropylene, other colours.
- Box Quantity: According to your request.

# Guide rail brackets

## Guide rail bracket (with adjustable high type head) Part. 280

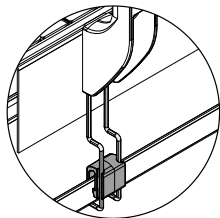

Presetting for drip tray support (see on page 26)

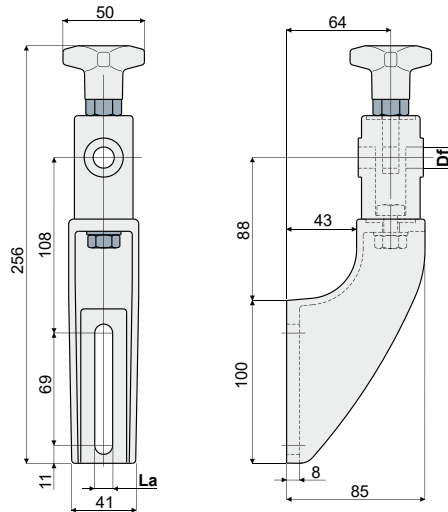

Df Bore for pin of (mm)	La (9 mm slot)	La (11 mm slot)
	Code	Code
12	280 / 82150	280 / 82127
14	280 / 82151	280 / 82128
16	280 / 82152	280 / 82129

**MATERIALS:** Bracket and knob made of reinforced polyamide black colour; hexagonal insert made of nickel plated brass; eyebolt, nut and washer made of stainless steel AISI 304.

**FEATURES:** Max tightening torque 4 Kg-m.

**BOX QUANTITY:** 24 pieces.

**ON REQUEST:**

- Brackets: In reinforced polypropylene, other colours.
- Box Quantity: According to your request.

## Guide rail bracket (reinforced type with adjustable high type head) Part. 281

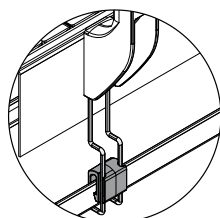

Presetting for drip tray support (see on page 26)

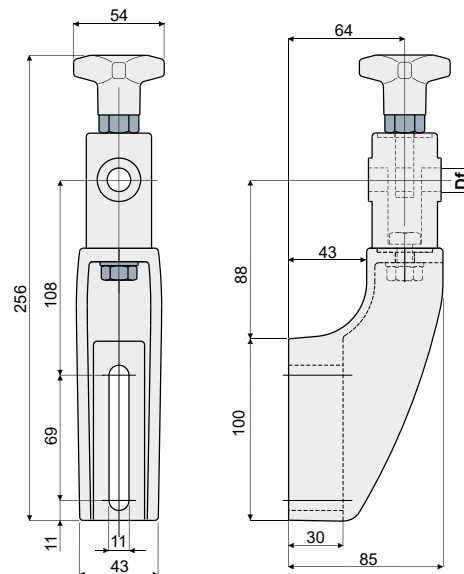

Df Bore for pin of (mm)	Code
12	281 / 82130
14	281 / 82131
16	281 / 82132

**MATERIALS:** Bracket and knob made of reinforced polyamide black colour; hexagonal insert made of nickel plated brass; eyebolt, screw, nut and washer made of stainless steel AISI 304.

**FEATURES:** To be used for heavy applications, suitable in conveyors with more ways, both in accumulation and curve. Max tightening torque 4 Kg-m.

**BOX QUANTITY:** 24 pieces.

**ON REQUEST:**

- Brackets: In reinforced polypropylene, other colours.
- Box Quantity: According to your request.

# Guide rail brackets

## Part. 279 Guide rail bracket (with adjustable head)

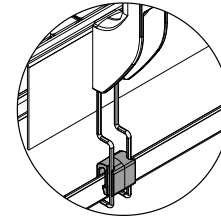
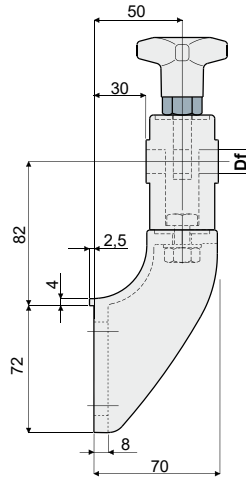
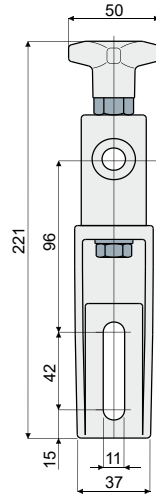

Presetting for drip tray support (see on page 26)

Df Bore for pin of (mm)	Code
12	279 / 82124
14	279 / 82125
16	279 / 82126

**MATERIALS:** Bracket and knob made of reinforced polyamide black colour; hexagonal insert made of nickel plated brass; eyebolt, nut and washer made of stainless steel AISI 304.

**FEATURES:** Max tightening torque 4 Kg-m.

**BOX QUANTITY:** 24 pieces.

**ON REQUEST:**

- Brackets: In reinforced polypropylene, other colours.
- Box Quantity: According to your request.

## Part. 216 Guide rail bracket (with metal adjustable head)

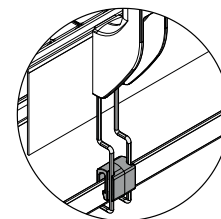
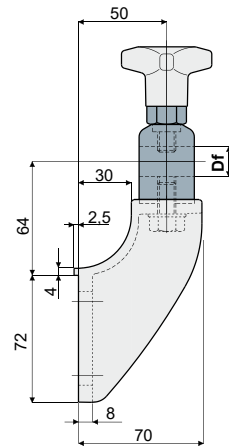
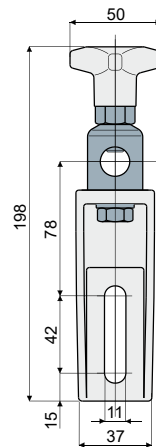

Presetting for drip tray support (see on page 26)

Df Bore for pin of (mm)	Head made out of nickel plated brass Code	Head made out of stainless steel AISI 304 Code
14 - 16	216 / 80758	216 / 80759

**MATERIALS:** Bracket and knob made out of reinforced polyamide black colour; head made out of stainless steel AISI 304 or nickel plated brass; hexagonal insert made out of nickel plated brass; screw and washer made out of stainless steel AISI 304.

**FEATURES:** Possibility to use pins with diameter 14 and 16 mm. Max tightening torque 4 Kg-m.

**BOX QUANTITY:** 24 pieces.

**ON REQUEST:**

- Brackets: In reinforced polypropylene, other colours.
- Box Quantity: According to your request.

# Guide rail brackets

## Guide rail bracket (with metal adjustable head) Part. 218

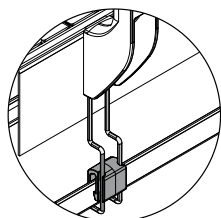

Presetting for drip tray support (see on page 26)

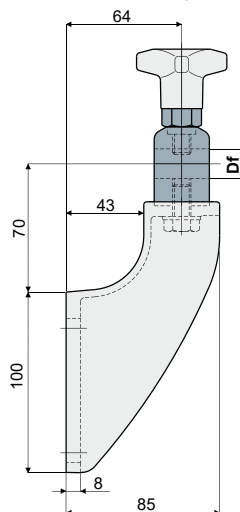
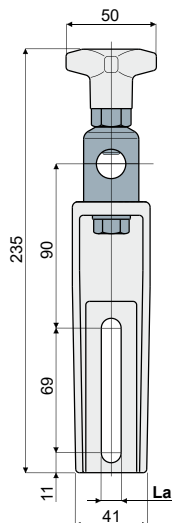

Df Bore for pin of (mm)	La (9 mm slot) Head made out of nickel plated brass Code	Head made out of stainless steel AISI 304 Code
14 - 16	218 / 82112	218 / 82113

Df Bore for pin of (mm)	La (11 mm slot) Head made out of nickel plated brass Code	Head made out of stainless steel AISI 304 Code
14 - 16	218 / 80662	218 / 80663

**MATERIALS:** Bracket and knob made out of reinforced polyamide black colour; head made out of stainless steel AISI 304 or nickel plated brass; hexagonal insert made out of nickel plated brass; screw and washer made out of stainless steel AISI 304.

**FEATURES:** Possibility to use pins with diameter 14 and 16 mm. Max tightening torque 4 Kg-m.

**BOX QUANTITY:** 24 pieces.

**ON REQUEST:**

- Brackets: In reinforced polypropylene, other colours.
- Box Quantity: According to your request.

## Guide rail bracket (reinforced type with metal adjustable head) Part. 244

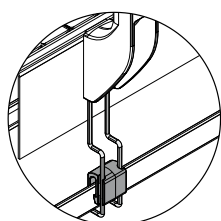

Presetting for drip tray support (see on page 26)

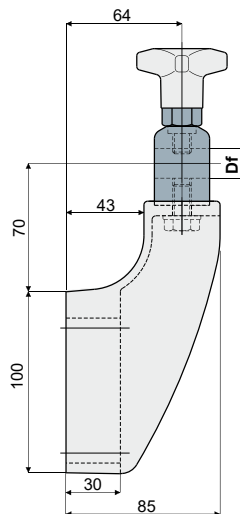
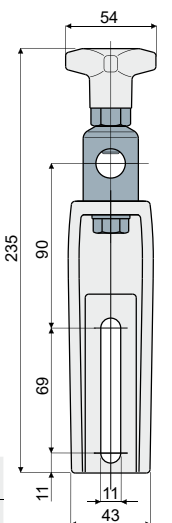

Df Bore for pin of (mm)	Head made out of nickel plated brass Code	Head made out of stainless steel AISI 304 Code
14 - 16	244 / 81006	244 / 81007

**MATERIALS:** Bracket and knob made out of reinforced polyamide black colour; head made out of stainless steel AISI 304 or nickel plated brass; hexagonal insert made out of nickel plated brass; screw and washer made out of stainless steel AISI 304.

**FEATURES:** To be used for heavy applications, suitable in conveyors with more ways, both in accumulation and curve. Possibility to use pins with diameter 14 and 16 mm. Max tightening torque 4 Kg-m.

**BOX QUANTITY:** 24 pieces.

**ON REQUEST:**

- Brackets: In reinforced polypropylene, other colours.
- Box Quantity: According to your request.

# Guide rail brackets

## Part. 255 Guide rail bracket (reinforced type with adjustable head)

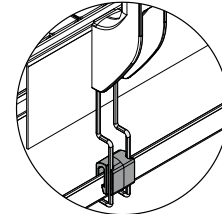
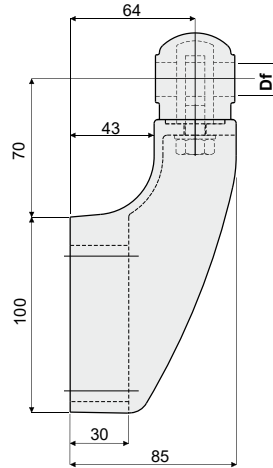
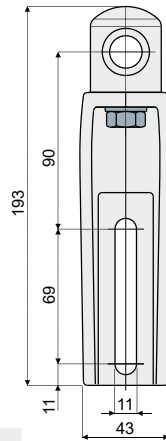

Presetting for drip tray support (see on page 26)

Df Bore for pin of (mm)	Code
12	255 / 81008
14	255 / 81009
16	255 / 81010

**MATERIALS:** Bracket and head made of reinforced polyamide black colour; eyebolt, nut and washer made of stainless steel AISI 304.

**FEATURES:** To be used for heavy applications, suitable in conveyors with more ways, both in accumulation and curve. Max tightening torque 4 Kg-m.

**BOX QUANTITY:** 24 pieces.

**ON REQUEST:**

- Brackets: In reinforced polypropylene, other colours.
- Box Quantity: According to your request.

## Part. 219 Guide rail bracket (with adjustable head)

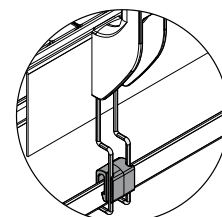
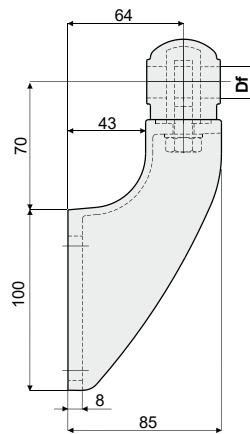
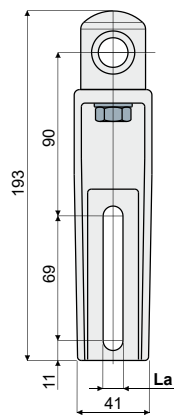

Presetting for drip tray support (see on page 26)

Df Bore for pin of (mm)	La (9 mm slot) Code	La (11 mm slot) Code
12	219 / 82114	219 / 80664
14	219 / 82115	219 / 80665
16	219 / 82116	219 / 80666

**MATERIALS:** Bracket and head made of reinforced polyamide black colour; eyebolt, nut and washer made of stainless steel AISI 304.

**FEATURES:** Max tightening torque 4 Kg-m.

**BOX QUANTITY:** 24 pieces.

**ON REQUEST:**

- Brackets: In reinforced polypropylene, other colours.
- Box Quantity: According to your request.

# Guide rail brackets

## Guide rail bracket (with adjustable head)

Part. **217**

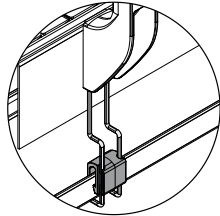

Presetting for  
drip tray support  
(see on page 26)

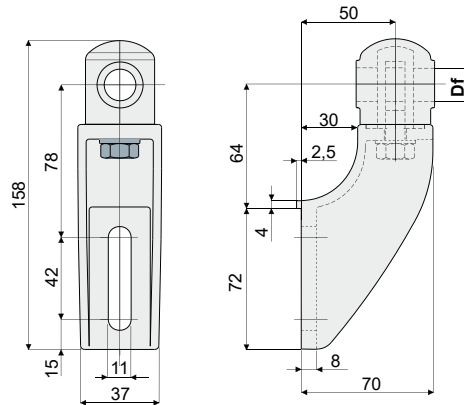

Df Bore for pin of (mm)	Code
12	217 / 80760
14	217 / 80761
16	217 / 80762

**MATERIALS:** Bracket and head made of reinforced polyamide black colour; eyebolt, nut and washer made of stainless steel AISI 304.

**FEATURES:** Max tightening torque 4 Kg-m.

**BOX QUANTITY:** 24 pieces.

**ON REQUEST:**

- Brackets: In reinforced polypropylene, other colours.
- Box Quantity: According to your request.

## Guide rail bracket (for adjustable heads)

Part. **209**

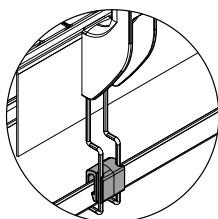

Presetting for  
drip tray support  
(see on page 26)

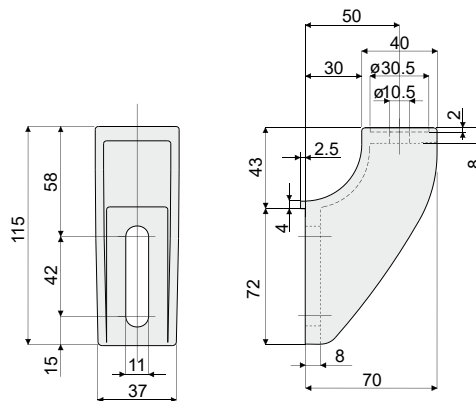

Code
209 / 80754

**MATERIALS:** Bracket made out of reinforced polyamide black colour.

**FEATURES:** To be used with heads Part.221, 222, 223 and 266.

**BOX QUANTITY:** 24 pieces.

**ON REQUEST:**

- Brackets: In reinforced polypropylene, other colours.
- Box Quantity: According to your request.

# Guide rail brackets

## Part. 220 Guide rail bracket (for adjustable heads)

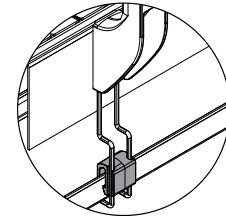
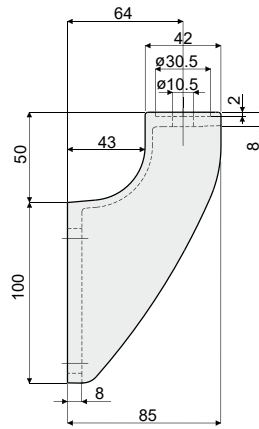
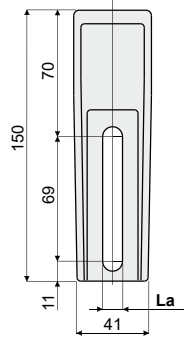

Presetting for drip tray support  
(see on page 26)

La (9 mm slot)	La (11 mm slot)
Code	Code
220 / 82111	220 / 80667

**MATERIALS:** Bracket made out of reinforced polyamide black colour.

**FEATURES:** To be used with heads Part.221, 222, 223 and 266.

**BOX QUANTITY:** 24 pieces.

**ON REQUEST:**

- Brackets: In reinforced polypropylene, other colours.
- Box Quantity: According to your request.

## Part. 242 Guide rail bracket (reinforced type for adjustable head)

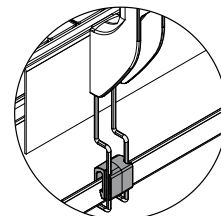
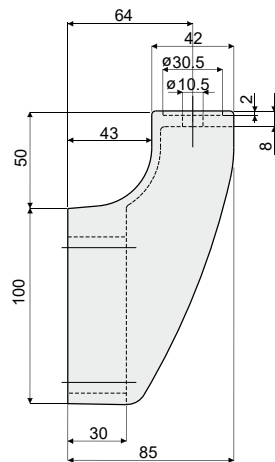
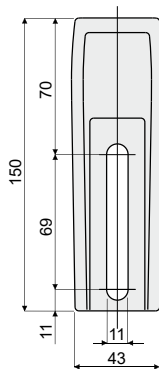

Presetting for drip tray support  
(see on page 26)

Code
242 / 81002

**MATERIALS:** Bracket made of reinforced polyamide black colour.

**FEATURES:** To be used with heads Part.221, 222, 223 and 266 for heavy applications.

Suitable in conveyors with more ways, both in accumulation and curve.

**BOX QUANTITY:** 24 pieces.

**ON REQUEST:**

- Brackets: In reinforced polypropylene, other colours.
- Box Quantity: According to your request.



# Guide rail brackets

## Spacer for bracket Part. **224**

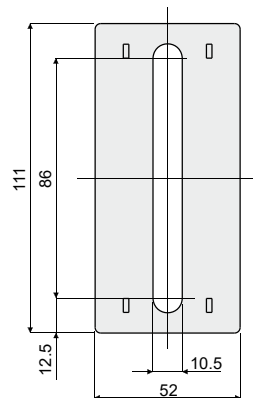

Code
224 / 80676

**MATERIALS:** Spacer made of reinforced polyamide black colour.

**FEATURES:** Accessory to be used with brackets Part.215, 218, 219, 220, 242, 243, 244, 255, 280, 281.

**BOX QUANTITY:** 24 pieces.

**ON REQUEST:**

- Spacers: In reinforced polypropylene, other colours.
- Box Quantity: According to your request.

## Spacer for bracket Part. **225**

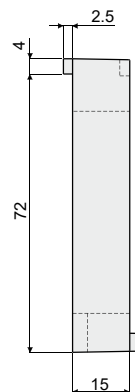
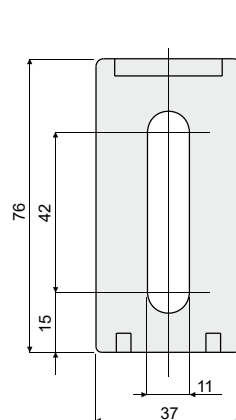

Code
225 / 80677

**MATERIALS:** Spacer made of reinforced polyamide black colour.

**FEATURES:** Accessory to be used with brackets Part.213, 214, 216, 217, 209, 279.

**BOX QUANTITY:** 24 pieces.

**ON REQUEST:**

- Spacers: In reinforced polypropylene, other colours.
- Box Quantity: According to your request.