

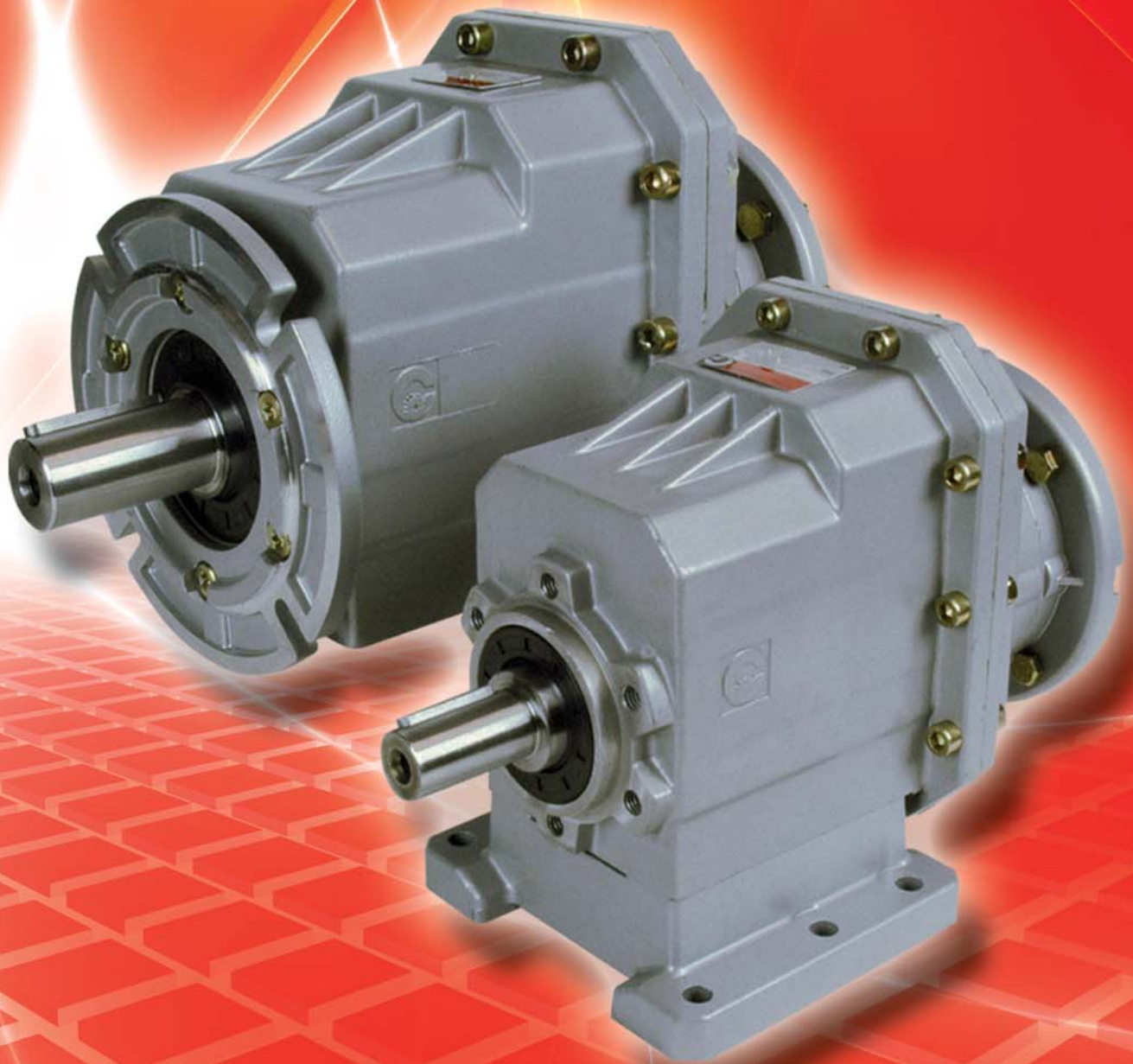

CHIARAVALLI

SpA



RIDUTTORI COASSIALI CHC

CHC SERIES HELICAL GEAR UNITS

PREMESSA

La nuova serie di riduttori coassiali denominata CHC è un prodotto che deve la sua innovazione alla modularità. Grazie alla predisposizione per motore IEC B5 e B14, può essere collegato a motori normali, autofrenanti ed antideflagranti.

Questo tipo di riduttore è largamente usato in campo tessile, alimentare, enologico, chimico, imballaggio, ecc.

CARATTERISTICHE PRODOTTO

- Modularità
- Alto rendimento
- Bassa rumorosità
- Montaggio universale
- Cassa in alluminio, peso ridotto
- **Ingranaggi cementati, rettificati**
- Lubrificazione permanente

I riduttori serie CHC sono prodotti in 5 grandezze (+ 1 a richiesta). Potenze 0,12-4 Kw rapporti da 5 a 46. Coppia max 120-500 Nm. Possono essere montati (a piedi o flangia) in tutte le posizioni secondo le richieste dei clienti.

INTRODUCTION

CHC series helical gear units is a new generation product, which designed basing on the modular system. It can be connected respectively with motors such as normal motor, brake motor, explosion-proof motor, IECmotor B5 - B14. This kind of product is widely used in drive fields such as textile, foodstuff, beverage, chemical industry, packaging and so on.

PRODUCTS CHARACTERISTICS

- Modularity
- High efficiency
- Low noise
- Universal mounting
- Aluminum housing, light in weight
- **Gears in carbonize hard, grinded**
- Lubricant maintenance free

CHC Series helical gear units are manufactured in 5 sizes (+ 1 on request). Power 0.12-4KW; Ratio 5-46; Torque max 120-500 Nm. It can be connected (foot, flange) discretionary and use multi-mounting positions according to cutomers' requirements.

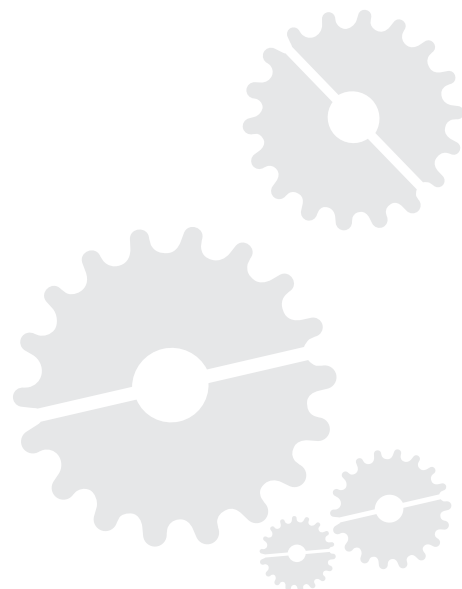

POSSIBILITA' DI ASSEMBLAGGIO - ASSEMBLING POSSIBILITY

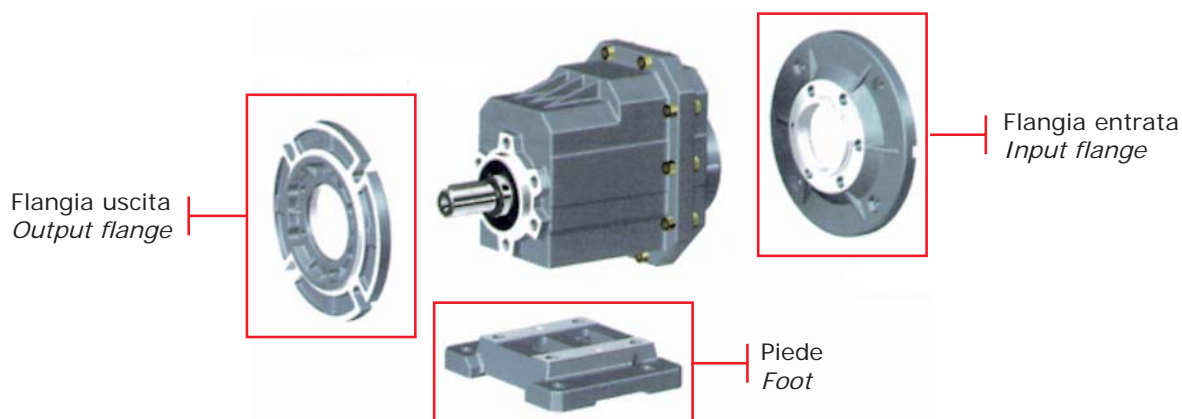

DESIGNAZIONE - DESIGNATION

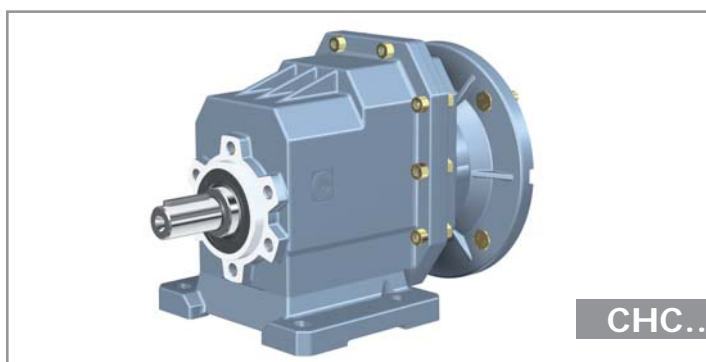

ESEMPIO ORDINE
ORDER EXAMPLE

CHC 25PB 28,9 80B5 B3

Tipo - Type *CHC*
 Grandezza - Size *16*-20-25-30-35-40*
 Il numero indica il diametro albero di uscita *The number indicates the output shaft diameter*

*CHC 16 a richiesta - *CHC 16 on request

Versione - Version
 P piede - foot
 F flangia - flange
 - no piede - no foot
 - no flangia - no flange

Tipo flangia
Flange type 1 2 3

Tipo piede
Foot type M / B / C

Rapporto - Ratio IEC vedi catalogo - see catalogue
 Motor flange size

Versione - Version B5 or B14
 Posizione montaggio
Mounting position B3 B8 B6 B7
 V5 V6 B5 V1 V3

Nel caso venga richiesto anche il motore specificare
 If the motor is also required please specify

Grandezze - Size es. 71B4
 Potenza - Power es. Kw. 0,37
 Poli - Poles es. 4
 Volt - Voltage es. 230 / 400
 Frequenza - Frequency es. 50 Hz.
 Flangia - Flange es. B5

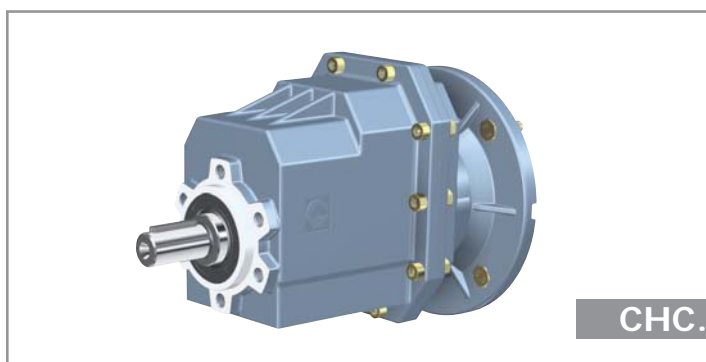
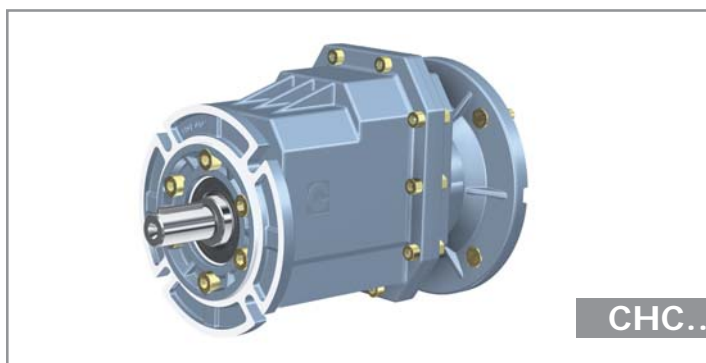

INFORMAZIONI GENERALI - GENERAL INFORMATION

POTENZA P - POWER P

$$P_1 \cdot \eta = P_2$$

P_1 = Potenza entrata · *Input power*

P_2 = Potenza uscita · *Output power*

η = Rendimento · *Transmission efficiency*

VELOCITA' DI ROTAZIONE n - ROTATION SPEED n

n_1 = Velocità entrata · *Input speed*

n_2 = Velocità uscita · *Output speed*

Al fine di ottimizzare le condizioni di lavoro e prolungare la durata del riduttore si consiglia una velocità di entrata ≤ 1400 rpm

Sono ammesse velocità superiori in accordo alla sottostante tabella.

An output speed ≤ 1400 rpm is suggested so as to optimize the working condition and extend the service life. Input speed higher are allowed following the table below.

n. RPM	POTENZA - POWER
1400	Kw
2000	Kw * 1,35
2800	Kw * 1,8

RAPPORTO DI TRASMISSIONE i - TRANSMISSION RATIO i

$$i = \frac{n_1}{n_2}$$

COPPIA M - TORQUE M

$$M_2 = \frac{9550 \cdot P_1 \cdot \eta}{n_2} \text{ [Nm]}$$

$$M_2 \geq M_2 \cdot f_s \text{ [Nm]}$$

M_2 = Coppia uscita	<i>Output torque</i>
M_{2n} = Coppia nominale uscita	<i>Rated output torque</i>
P_1 = Potenza entrata	<i>Input power</i>
η = Rendimento	<i>Transmission efficiency</i>
f_s = Fattore di servizio	<i>Service factor</i>

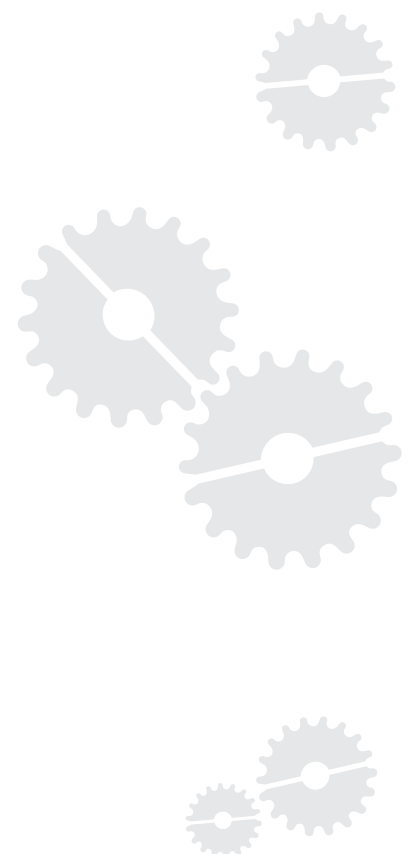

CARICHI RADIALI F_R - RADIAL LOADS F_R

Il carico radiale è proporzionale alla coppia richiesta ed inversamente proporzionale al diametro dell'elemento di trasmissione secondo la sottostante formula.

The radial loads is proportional to the requested torque and inversely proportional to the transmission member diameter following this formula.

$$F_R = \frac{2000 \cdot T \cdot T.e.f.}{D} \quad [N]$$

F_R	= Carico radiale	<i>Radial load</i>
T	= Nm (Coppia)	<i>Nm (Torque)</i>
T.e.f.	= Fattore elemento di trasmissione	<i>Transmission element factor</i>
T.e.f.	= 1,15 ingranaggio	<i>1,15 gear</i>
	= 1,4 pignone per catena	<i>1,4 chain sprocket</i>
	= 1,75 puleggia a gola	<i>1,75 v-pulley</i>
	= 2,5 puleggia piana	<i>2,5 flat-pulley</i>
D	= Diametro elemento di trasmissione	<i>Transmission element diameter</i>

Quando il carico radiale non è applicato sulla mezzeria dell'albero bisogna usare la sottostante formula.

When the radial loads is not applied on the centre line of the shaft it is necessary to use the following formula.

$$F_{Rx} \leq \frac{F_R \cdot a}{(b+x)} \quad [N]$$

F_R	= Carico radiale mezzeria	<i>Radial load on the centre line</i>
a, b, x	= vedi tabella	<i>See table</i>

VALORI DELLE COSTANTI - CONSTANTS' VALUES

	CHC 16-20	CHC 25	CHC 30	CHC 35-40
a	103	116,5	130	147
b	83	91,5	100	112

Carichi radiali albero lento & carichi assiali F_R, F_A

Output shafts radial loads & axial loads F_R, F_A

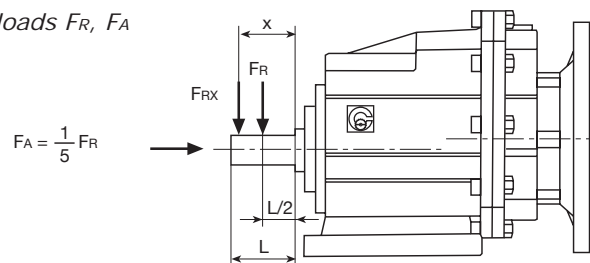

n_2 [min ⁻¹]	10	40	60	80	100	120	150	180	250	400
F_R	2300	2300	2180	1980	1840	1630	1400	1320	1080	920
	4800	4800	4370	3970	3680	3470	2710	2550	2150	1840
	6300	6300	5550	5040	4510	3800	3530	3320	2800	2390
	7500	7500	6590	5990	5230	4570	4240	3900	3350	2860



LUBRIFICAZIONE - LUBRICATION

TIPO DI LUBRIFICAZIONE - TYPES OF LUBRICATION

		ISO	SHELL	MOBIL	BP	Tipo lubrificante Lubrication type
CHC	-10 to +40	VG 220	Shell Omala 220	Mobilgear 630	BP Energol GR-XP 220	Olio Minerale Mineral Oil
	-20 to +25	VG 150 VG 100	Shell Omala 100	Mobilgear 627	BP Energol GR-XP 100	
	-30 to +10	VG 68-46 VG 32	Shell Tellus T 32	Mobil D.T.E. 13M		
	-40 to -20	VG 22 VG 15	Shell Tellus T 15	Mobil D.T.E. 11M	BP Energol HLP-HM 15	
	-40 to +40	VG 150	Shell Omala HD 150	Mobil SHC 629		Olio sintetico Syntetic oil
	-40 to +80	VG 220	Shell Omala HD 220	Mobil SHC 630		
	-25 to +50	VG 320	Shell Tivela S 320			

POSIZIONE DI MONTAGGIO E POSIZIONE MORSETTERIA MOUNTING POSITION AND TERMINAL BOX ORIENTATION

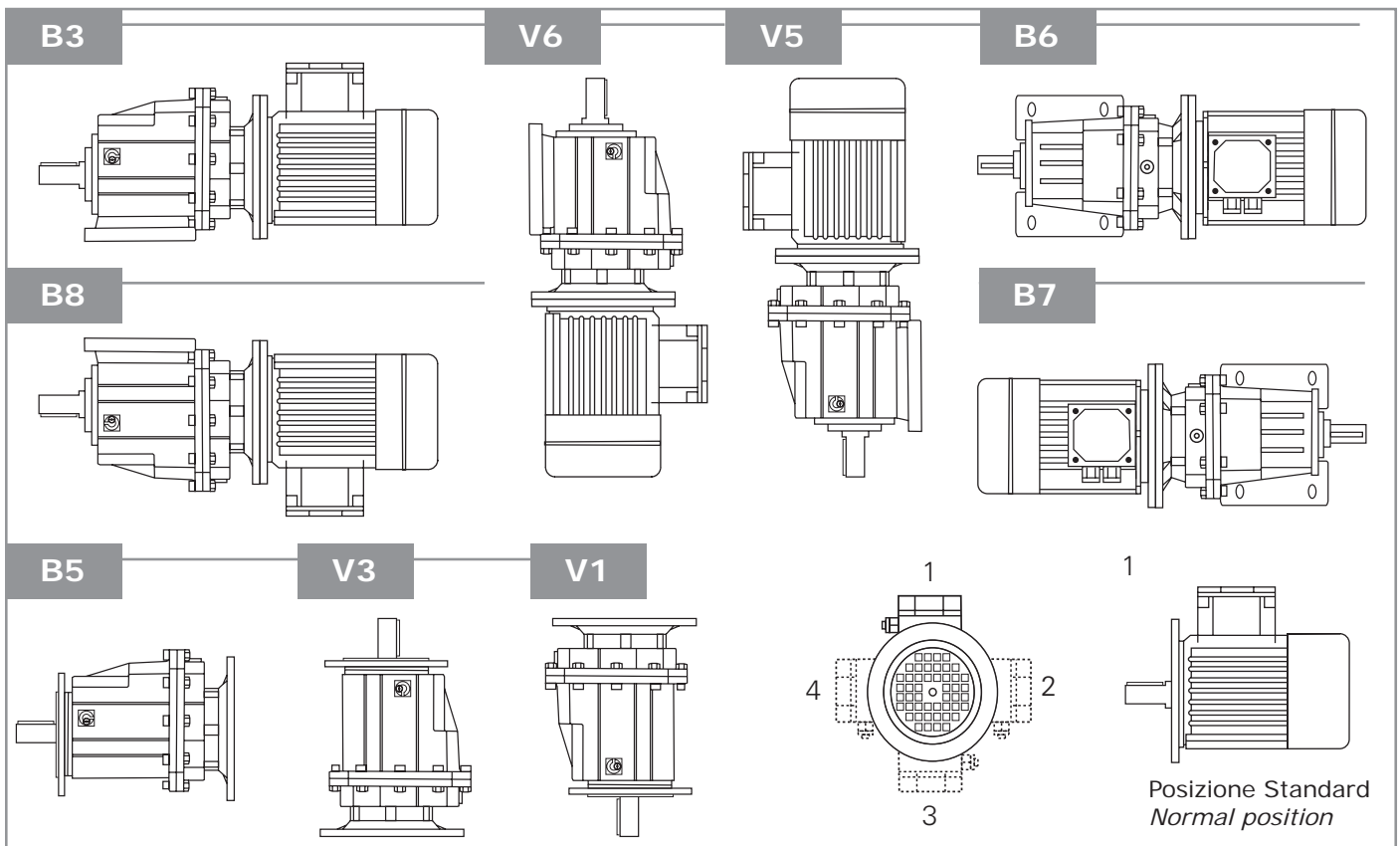

Grandezza Quantità in litri / Fill quantity in litres

Size	STANDARD	V6/V3
CHC 16/20	0,4	0,6
CHC 25	0,5	0,7
CHC 30	0,8	1,1
CHC 35/40	1,2	1,6

I riduttori CHC sono forniti completi di lubrificante Shell Tivela S 320 per la posizione standard, se montati in V6/V3 si dovrà aggiungere la quantità di olio necessaria.

The CHC gearboxes are supplied with Shell Tivela S 320 oil for STANDARD position, when mounted in V6/V3 it is necessary to add the correct quantity of oil.

Posizione Standard
Normal position

RAPPORTI E PREDISPOSIZIONI POSSIBILI

RATIO AND IEC MOTOR ADAPTERS

CHC 20	(CHC16)*	IEC	
i	63B5	71B5 71B14	80B5 80B14
45,9	B		
40,1	B		
35,5	B		
28,5	B		
23,6	B		
19,8	B		
17,9	B		
13,8	B		
11,9	B		
9,8	B		
7,7	B		
5,7	B		
4,6	B	B	

CHC 25	IEC		
i	71B5 71B14	80B5 80B14	90B5 90B14
46,5	B		
40,6	B		
35,9	B		
28,9	B		
23,9	B		
20,1		B	
17,1		B	
14,8		B	
12,1		B	
9,9		B	
7,4		B	
5,5		B	

CHC 30	IEC		
i	80B5 80B14	90B5 90B14	100/112B5 100/112B14
51,3			
44,2	B		
34,2	B		
30,6	B		
25,0	B		
21,2	B		
18,2	B	B	
15,3	B	B	
12,6		B	
10,9		B	
7,9		B	
5,5		B	

CHC 35	CHC 40	IEC	
i	80B5 80B14	90B5 90B14	100/112B5 100/112B14
51,3	B		
44,2	B		
34,2	B	B	
30,6		B	
25,0		B	
21,2		B	
18,2		B	
15,3		B	
12,6			
10,9			
7,9			
5,5			

* CHC 16 Solo a richiesta - *Only on request*

I rapporti sono arrotondati - *Ratios are rounded*

B= con boccola di riduzione in acciaio - *Metal reduction bushing*

IEC	63B5	71B5	71B14	80B5	80B14	90B5	90B14	100B5	100B14	112B5	112B14
DE8	11	14		19		24		28		28	
P	140	160	105	200	120	200	140	250	160	250	160
M	115	130	85	165	100	165	115	215	130	215	130
N	95	110	70	130	80	130	95	180	110	180	110



TABELLA DI SELEZIONE PRESTAZIONI

GEAR UNIT SELECTION TABLES

P_{1n} [kW]	n_2 [r/min]	M_{2n} [Nm]	i	f_s			page			
0.12	30.5	36	45.9	3.3	CHC20	63B5	63A4	16		
	34.9	32	40.1	3.8	(CHC16)					
	39.5	28	35.5	4.3						
	49.1	22	28.5	5.4						
	59.4	18.5	23.6	6.5						
	70.6	15.6	19.8	7.7						
	78.4	14.0	17.9	7.1						
	101	10.8	13.8	9.2						
	118	9.4	11.9	12.8						
	143	7.7	9.8	13.0						
	181	6.1	7.7	13.2						
	246	4.5	5.7	13.4						
	0.18	19.6	84	45.9	1.4	CHC20	71B5/B14		71A6	16
		22.4	74	40.1	1.6	(CHC16)				
25.4		65	35.5	1.8						
31.6		52	28.5	2.3						
30.5		54	45.9	2.2	CHC20	63B5	63B4	16		
34.9		47	40.1	2.5	(CHC16)					
39.5		42	35.5	2.9						
49.1		34	28.5	3.6						
59.4		28	23.6	4.3						
70.6		23	19.8	5.1						
78.4		21	17.9	4.8						
101		16.3	13.8	6.1						
118		14.0	11.9	8.6						
143		11.6	9.8	8.6						
181	9.1	7.7	8.8							
246	6.7	5.7	8.9							
19.4	85	46.5	2.3	CHC25	71B5/B14	71A6	17			
22.2	74	40.6	2.7							
25.1	66	35.9	3.0							
31.2	53	28.9	3.8							
30.1	55	46.5	3.7	CHC25	63B5	63B4	17			
34.5	48	40.6	4.2							
0.25	19.6	117	45.9	1.0	CHC20	71B5/B14	71B6	16		
	22.4	102	40.1	1.2	(CHC16)					
	25.4	90	35.5	1.3						
	31.6	73	28.5	1.7						
	30.5	75	45.9	1.6	CHC20	71B5/B14	71A4		16	
	34.9	66	40.1	1.8	(CHC16)					
	39.5	58	35.5	2.1						
	49.1	47	28.5	2.6						
	59.4	39	23.6	3.1						
	70.6	32	19.8	3.7						

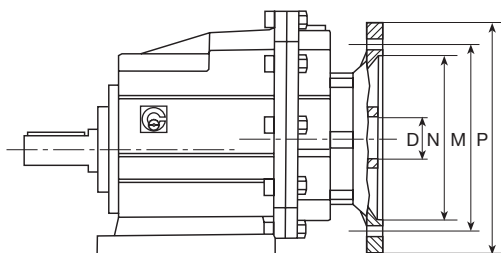
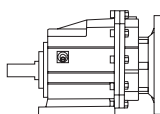
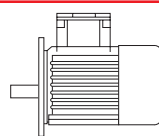
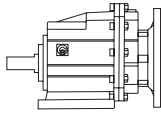
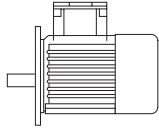

P_{1n} [kW]	n_2 [r/min]	M_{2n} [Nm]	i	f_s			page
------------------	------------------	------------------	-----	-------	--	---	------

0.25	78.4	29	17.9	3.4	CHC20	71B5/B14	71A4	16	
	101	23	13.8	4.4	(CHC16)				
	118	19.5	11.9	6.2					
	143	16.1	9.8	6.2					
	181	12.6	7.7	6.3					
	246	9.3	5.7	6.4					
	19.4	118	46.5	1.7	CHC25	71B5/B14	71B6	17	
	22.2	103	40.6	1.9					
	25.1	91	35.9	2.2					
	31.2	74	28.9	2.7					
	30.1	76	46.5	2.6	CHC25	71B5/B14	71A4	17	
	34.5	66	40.6	3.0					
	39.0	59	35.9	3.4					
	48.5	47	28.9	4.2					
0.37	30.5	111	45.9	1.1	CHC20	71B5/B14	71B4	16	
	34.9	97	40.1	1.2	(CHC16)				
	39.5	86	35.5	1.4					
	49.1	69	28.5	1.7					
	59.4	57	23.6	2.1					
	70.6	48	19.8	2.5					
	78.4	43	17.9	2.3					
	101	33	13.8	3.0					
	118	29	11.9	4.2					
	143	24	9.8	4.2					
	181	19	7.7	4.3					
	246	14	5.7	4.4					
	19.4	175	46.5	1.1	CHC25	80B4/B14	80A6	17	
		22.2	153	40.6	1.3				
		25.1	135	35.9	1.5				
		31.2	109	28.9	1.8				
		30.1	113	46.5	1.8	CHC25	71B5/B14	71B4	17
	34.5	98	40.6	2.0					
	39	87	35.9	2.3					
	48.5	70	28.9	2.9					
	58.7	58	23.8	3.5					
	81.9	41	17.1	3.9					
	20.4	167	44.2	1.8	CHC30	80B5/B14	80A6	18	
	26.3	129	34.2	2.3					
	29.4	115	30.6	2.6					
0.55	101	50	13.8	2.0	CHC20	80B5/B14	80A4	16	
	118	43	11.9	2.8	(CHC16)				
	143	35	9.8	2.8					
	181	28	7.7	2.9					
	246	20	5.7	2.9					

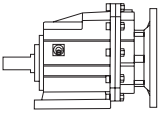
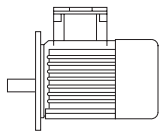

TABELLA DI SELEZIONE PRESTAZIONI GEAR UNIT SELECTION TABLES

P_{1n} [kW]	n_2 [r/min]	M_{2n} [Nm]	i	f_s			page	
0.55	19.4	260	46.5	0.8	CHC25	80B5/B14	80B6	17
	22.2	227	40.6	0.9				
	25.1	201	35.9	1.0				
	31.2	162	28.9	1.2				
	37.7	134	23.9	1.5				
	30.1	167	46.5	1.2	CHC25	80B5/B14	80A4	17
	34.5	146	40.6	1.4				
	39	129	35.9	1.5				
	48.5	104	28.9	1.9				
	58.7	86	23.9	2.3				
	69.7	72	20.1	2.8				
	81.9	62	17.1	2.6				
	94.5	53	14.8	3.7				
	17.5	287	51.3	1.0	CHC30	80B5/B14	80B6	18
	20.4	248	44.2	1.2				
	26.3	192	34.2	1.6				
	29.4	171	30.6	1.8				
	27.3	185	51.3	1.6	CHC30	80B5/B14	80A4	18
	31.7	159	44.2	1.9				
	40.9	123	34.2	2.4				
0.75	45.8	110	30.6	2.7				
	101	68	13.8	1.5	CHC20	80B5/B14	80B4	16
	118	58	11.9	2.1	(CHC16)			
	143	48	9.8	2.1				
	181	38	7.7	2.1				
	246	28	5.7	2.1				
	302	23	4.6	2.6				
	30.1	228	46.5	0.9	CHC25	80B5/B14	80B4	17
	34.5	199	40.6	1.0				
	39	176	35.9	1.1				
	48.5	142	28.9	1.4				
	58.7	117	23.9	1.7				
	69.7	99	20.1	2.0				
	81.9	84	17.1	1.9				
	94.5	73	14.8	2.7				
	116.2	59	12.1	3.4				
	141	49	9.9	3.3				
	189	36	7.4	3.3				
	257	27	5.5	3.7				
	20.4	338	44.2	0.9	CHC30	90B5/B14	90S6	18
	26.3	261	34.2	1.1				
	29.4	234	30.6	1.3				
	36	191	25.0	1.6				
	27.3	252	51.3	1.2	CHC30	80B5/B14	80B4	18

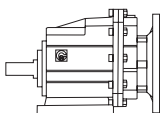
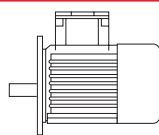

P_{1n} [kW]	n_2 [r/min]	M_{2n} [Nm]	i	f_s			page
------------------	------------------	------------------	-----	-------	--	---	------

0.75	31.7	217	44.2	1.4	CHC30	80B5/B14	80B4	18
	40.9	168	34.2	1.8				
	45.8	150	30.6	2.0				
	56	123	25.0	2.4				
	66.2	104	21.2	2.7				
	76.9	89	18.2	3.1				
	91.5	75	15.3	3.7				
	17.5	392	51.3	1.3	CHC35	90B5/B14	90S6	19
	20.4	338	44.2	1.5	CHC40			
	26.3	261	34.2	1.8				
	29.4	234	30.6	2.1				
	27.3	252	51.3	2.0	CHC35	80B5/B14	80B4	
	31.7	217	44.2	2.3	CHC40			
	40.9	168	34.2	2.9				
1.1	101	99	13.8	1.0	CHC20	80B5/B14	80C4	16
	118	86	11.9	1.4	(CHC16)			
	143	71	9.8	1.4				
	181	56	7.7	1.4				
	246	41	5.7	1.5				
	302	33	4.6	1.8				
	48.5	208	28.9	1.0	CHC25	80B5/B14	80C4	
	58.7	172	23.9	1.2				
	69.7	145	20.1	1.4	CHC25	90B5/B14	90S4	17
	81.9	123	17.1	1.3				
	94.5	107	14.8	1.9				
	116	87	12.1	2.3				
	141	72	9.9	2.2				
	189	53	7.4	2.3				
257	39	5.5	2.5					
	31.7	318	44.2	0.9	CHC30	90B5/B14	90S4	18
	40.9	246	34.2	1.2				
	45.8	220	30.6	1.4				
	56	180	25.0	1.7				
	66.2	152	21.2	1.8				
	76.9	131	18.2	2.1				
	91.5	110	15.3	2.5				
	27.3	370	51.3	1.4	CHC35	90B5/B14	90S4	19
	31.7	318	44.2	1.6	CHC40			
	40.9	246	34.2	1.9				
	45.8	220	30.6	2.2				
	56	180	25.0	2.7				
	66.2	152	21.2	2.8				
	76.9	131	18.2	3.2				
91.5	110	15.3	3.8					



TABELLA DI SELEZIONE PRESTAZIONI

GEAR UNIT SELECTION TABLES

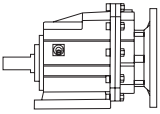
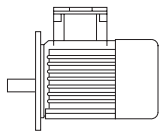
P_{1n} [kW]	n_2 [r/min]	M_{2n} [Nm]	i	f_s			page	
1.5	69.7	197	20.1	1.0	CHC25	90B5/B14	90L4	17
	81.9	168	17.1	1.0				
	94.5	145	14.8	1.4				
	116	118	12.1	1.7				
	141	98	9.9	1.6				
	189	73	7.4	1.7				
1.5	257	54	5.5	1.9	CHC25	90B5/B14	90L4	17
	40.9	336	34.2	0.9	CHC30	90B5/B14	90L4	18
	45.8	300	30.6	1.0				
	56	245	25.0	1.2				
	66.2	208	21.2	1.3				
	76.9	179	18.2	1.6				
	91.5	150	15.3	1.9				
	111	124	12.6	2				
	128	107	10.9	1.7				
	177	78	7.9	2.3				
	255	54	5.5	2.8				
	26.3	523	34.2	0.9	CHC35	100B5/B14	100L6	19
	29.4	467	30.6	1	CHC40			
	36	382	25	1.3				
	27.3	504	51.3	1.0	CHC35	90B5/B14	90L4	19
31.7	434	44.2	1.2	CHC40				
40.9	336	34.2	1.4					
45.8	300	30.6	1.6					
56	245	25.0	2					
66.2	208	21.2	2					
76.9	179	18.2	2.3					
91.5	150	15.3	2.8					
2.2	76.9	262	18.2	1.1	CHC30	100B5/B14	100LA4	18
	91.5	220	15.3	1.1				
	111	182	12.6	1.4				
	128	157	10.9	1.1				
	177	114	7.9	1.6				
	255	79	5.5	1.9				
	36	560	25.0	0.9	CHC35	112B5/B14	112M6	19
	42.6	474	21.2	0.9	CHC40			
	49.4	408	18.2	1				
	40.9	493	34.2	1	CHC35	100B5/B14	100LA4	19
	45.8	440	30.6	1.1	CHC40			
	56	360	25.0	1.3				
	66.2	305	21.2	1.4				
	76.9	262	18.2	1.6				
	91.5	220	15.3	1.9				
111	182	12.6	1.9					



M_{2max} [Nm]	n_1 [r/min]	i	P_{1n} [kW]	n_2 [r/min]	
120	1400	45.9	0.40	30.5	CHC20
120	1400	40.1	0.46	34.9	(CHC16)
120	1400	35.5	0.52	39.5	
120	1400	28.5	0.64	49.1	
120	1400	23.6	0.78	59.4	
120	1400	19.8	0.92	70.6	
100	1400	17.9	0.86	78.4	
100	1400	13.8	1.10	101	
120	1400	11.9	1.54	118	
100	1400	9.8	1.56	143	
80	1400	7.7	1.58	181	
60	1400	5.7	1.61	246	
60	1400	4.6	1.98	302	
200	1400	46.5	0.66	30.1	CHC25
200	1400	40.6	0.75	34.5	
200	1400	35.9	0.85	39.0	
200	1400	28.9	1.06	48.5	
200	1400	23.9	1.28	58.7	
200	1400	20.1	1.52	69.7	
160	1400	17.1	1.43	81.9	
200	1400	14.8	2.06	94.6	
200	1400	12.1	2.53	116	
160	1400	9.9	2.46	141	
120	1400	7.4	2.49	190	
100	1400	5.5	2.80	257	
300	1400	51.5	0.89	27.3	CHC30
300	1400	44.2	1.04	31.7	
300	1400	34.2	1.34	40.9	
300	1400	30.6	1.50	45.8	
300	1400	25.0	1.83	56.0	
280	1400	21.2	2.02	66.2	
280	1400	18.2	2.35	76.9	
280	1400	15.3	2.79	91.5	
250	1400	12.6	3.03	111	
180	1400	10.9	2.51	128	
180	1400	7.9	3.46	176	
150	1400	5.5	4.17	255	
500	1400	51.3	1.49	27.3	CHC35
500	1400	44.2	1.73	31.7	CHC40
480	1400	34.2	2.14	40.9	
480	1400	30.6	2.40	45.8	
480	1400	25.0	2.93	56.0	
420	1400	21.2	3.03	66.2	
420	1400	18.2	3.52	76.9	
420	1400	15.3	4.19	91.5	
350	1400	12.6	4.24	111	
280	1400	10.9	3.91	128	
260	1400	7.9	4.99	176	
230	1400	5.5	6.40	255	



DIMENSIONI - DIMENSION SHEET

CHC 20 (CHC16) P (IEC)

ENTRATA / INPUT

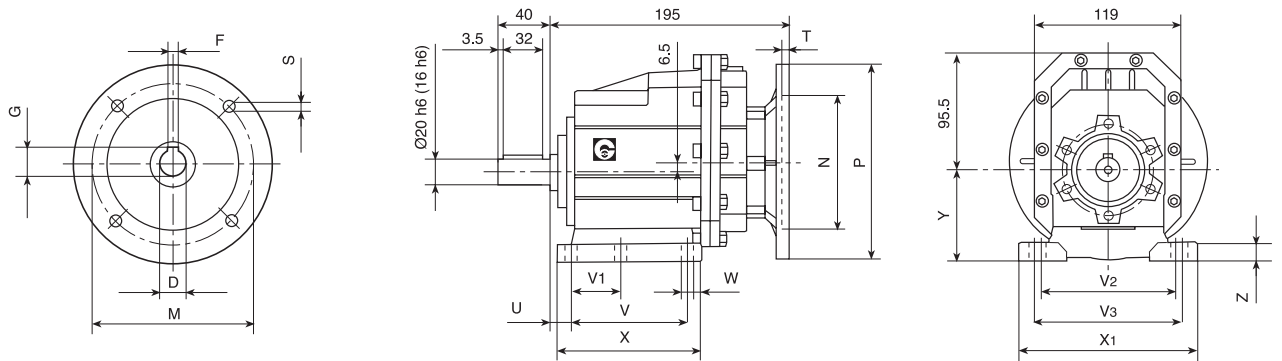

CHC 20 (CHC16) F (IEC)

USCITA / OUTPUT

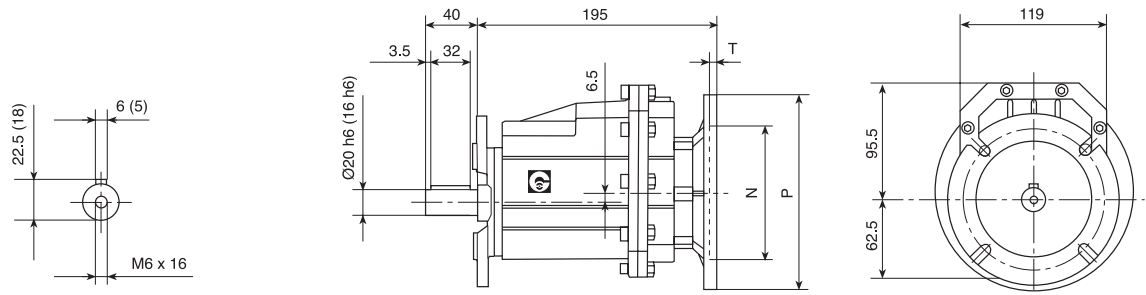

1
Ø120

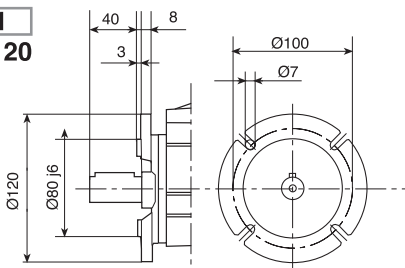

2
Ø140

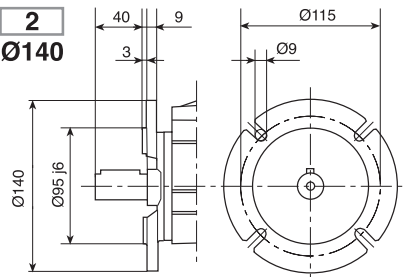

3
Ø160

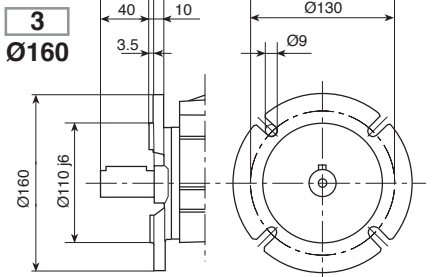

CHC 20 (CHC16) (IEC)

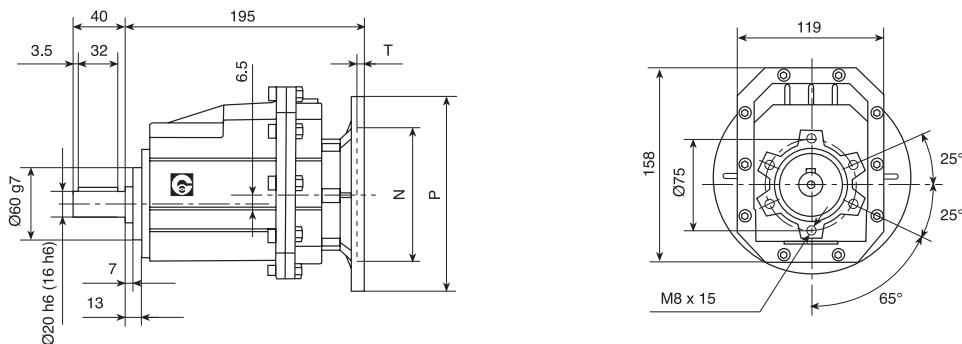

(CHC16) A richiesta
On request

kg. 4,7

IEC	D	F	G	P	M	N	S	T
63B5	11	4	12.8	140	115	95	9	5
71B5	14	5	16.3	160	130	110	9	5
71B14	14	5	16.3	105	85	70	7	5
80B5	19	6	21.8	200	165	130	11	5
80B14	19	6	21.8	120	100	80	7	5

Cod. Piede Foot cod.	U	V	V ₁	V ₂	V ₃	W	X	X ₁	Y	Z
B	18	87	50	110	-	9	118	130	85	15
M	18	80	-	110	120	9	118	145	75	15



DIMENSIONI - DIMENSION SHEET

CHC 25 P (IEC)

ENTRATA / INPUT

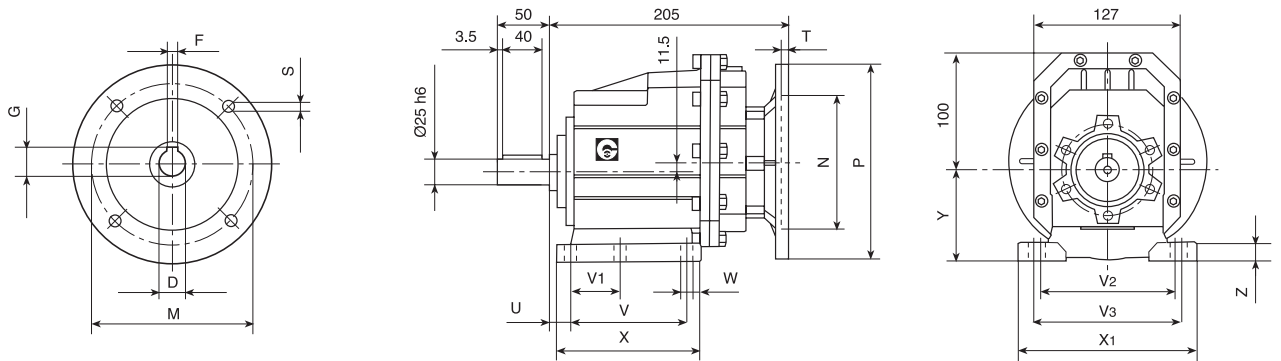

CHC 25 F (IEC)

USCITA / OUTPUT

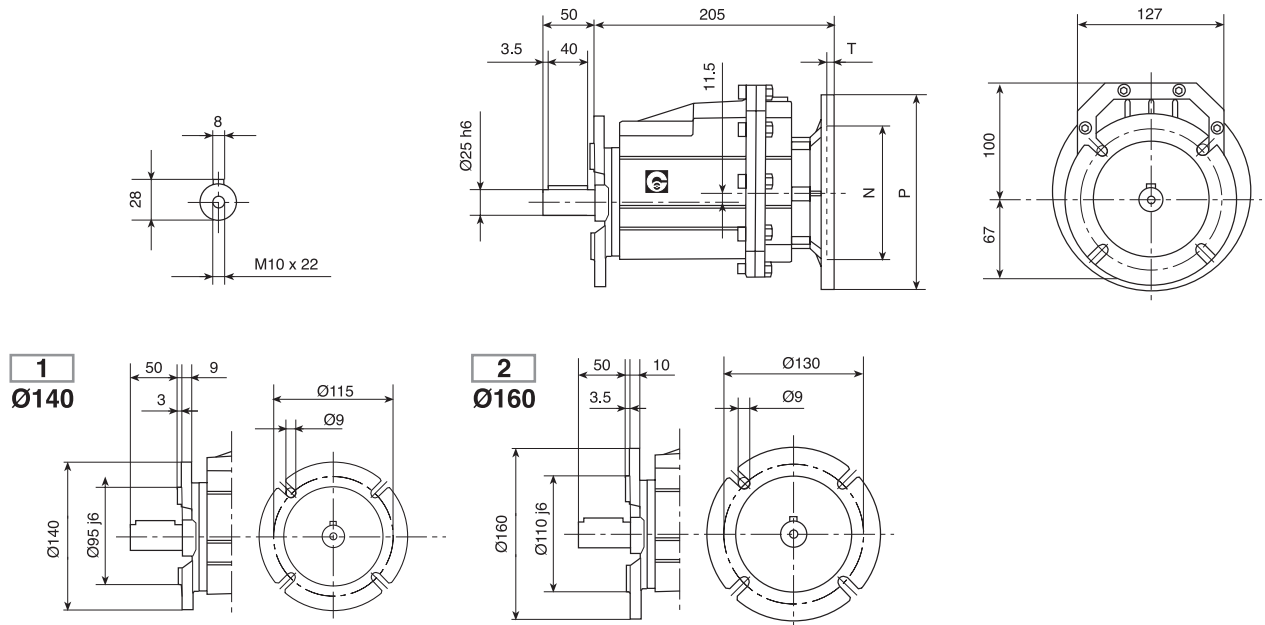

CHC 25 (IEC)

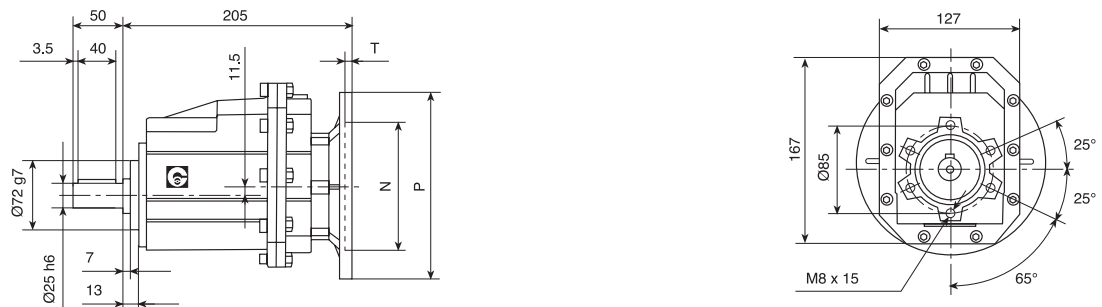

kg. 5,8

Cod. Piede Foot cod.	U	V	V ₁	V ₂	V ₃	W	X	X ₁	Y	Z
B	18	107.5	60	-	130	11	136	155	100	17
M	25	85	-	110	120	9	112	145	80	15

IEC	D	F	G	P	M	N	S	T
71B5	14	5	16.3	160	130	110	9	5
71B14	14	5	16.3	105	85	70	7	5
80B5	19	6	21.8	200	165	130	11	5
80B14	19	6	21.8	120	100	80	7	5
90B5	24	8	27.3	200	165	130	11	5
90B14	24	8	27.3	140	115	95	9	5

DIMENSIONI - DIMENSION SHEET

CHC 30 P (IEC)

ENTRATA / INPUT

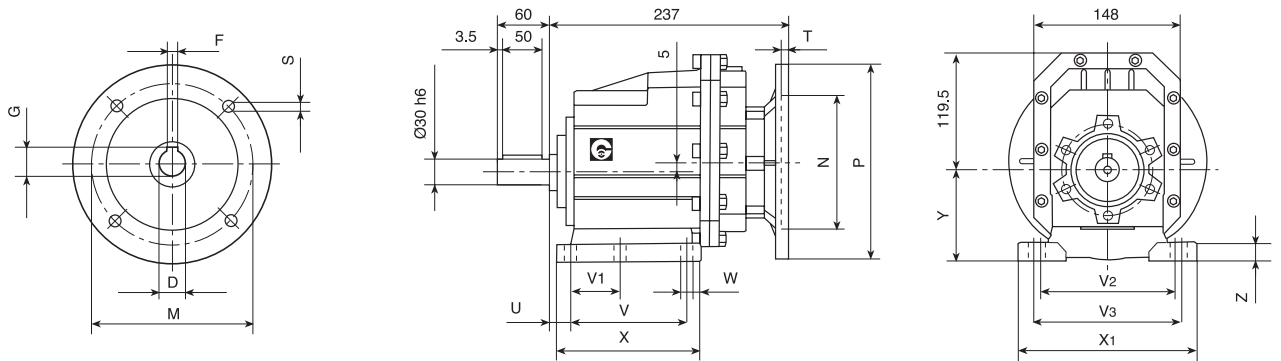

CHC 30 F (IEC)

USCITA / OUTPUT

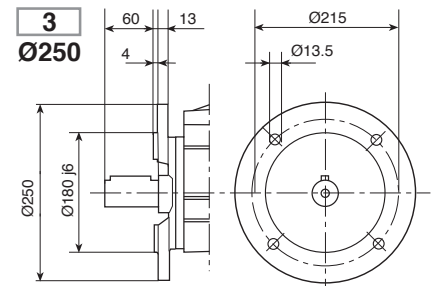
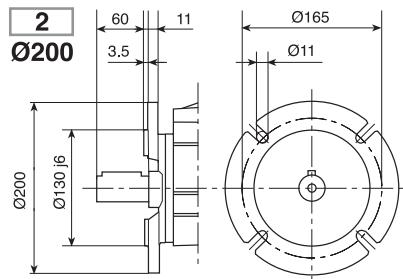
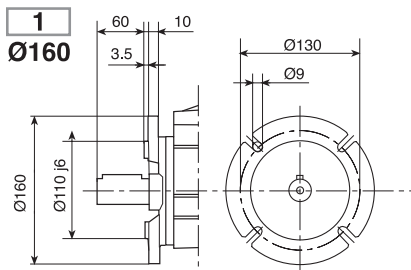
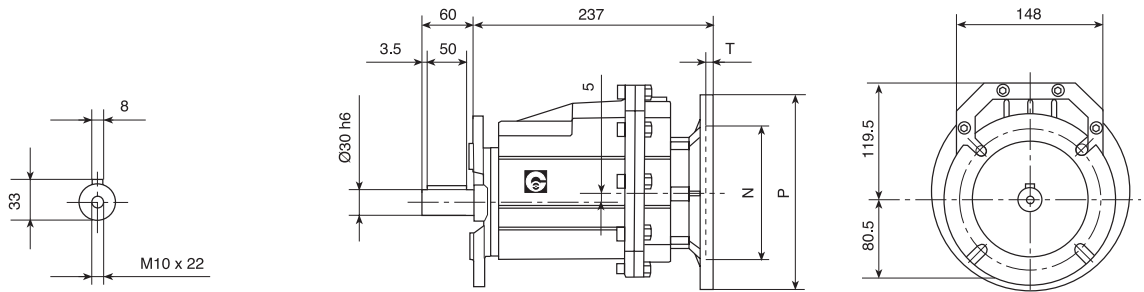

CHC 30 (IEC)

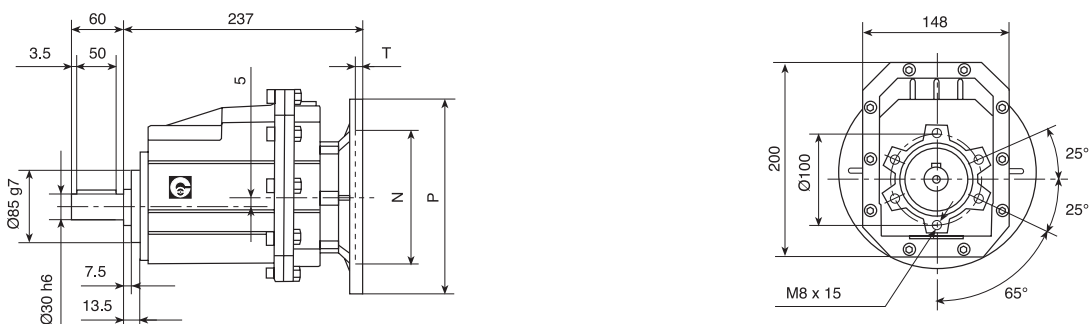

kg. 9,2

IEC	D	F	G	P	M	N	S	T
80B5	19	6	21.8	200	165	130	11	5
80B14	19	6	21.8	120	100	80	7	5
90B5	24	8	27.3	200	165	130	11	5
90B14	24	8	27.3	140	115	95	9	5
100/112B5	28	8	31.3	250	215	180	13.5	5
100/112B14	28	8	31.3	160	130	110	9	5

Cod. Piede Foot cod.	U	V	V1	V2	V3	W	X	X1	Y	Z
B	18	130	70	-	160	11	156	190	110	20
M	30	100	-	135	150	11	150	190	110	18



DIMENSIONI - DIMENSION SHEET

CHC 35 - CHC 40 P (IEC)

ENTRATA / INPUT

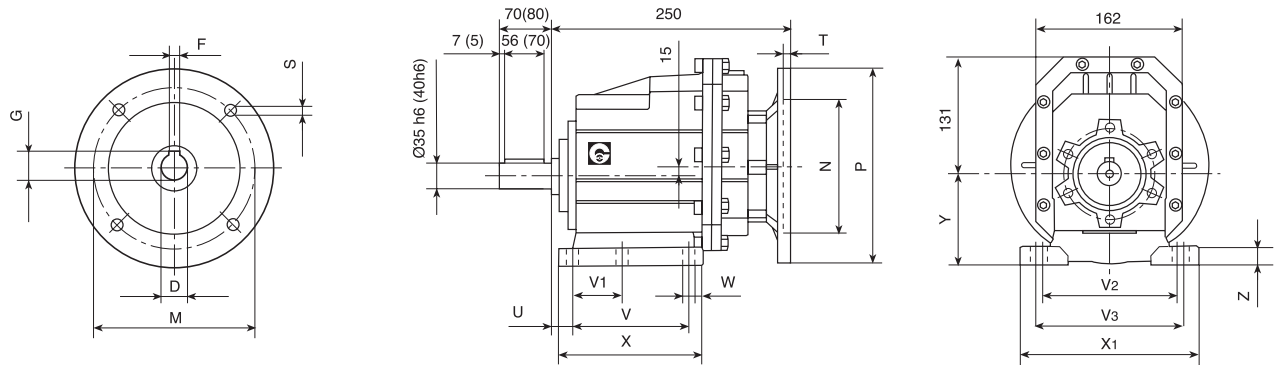

CHC 35 - CHC 40 F (IEC)

USCITA / OUTPUT

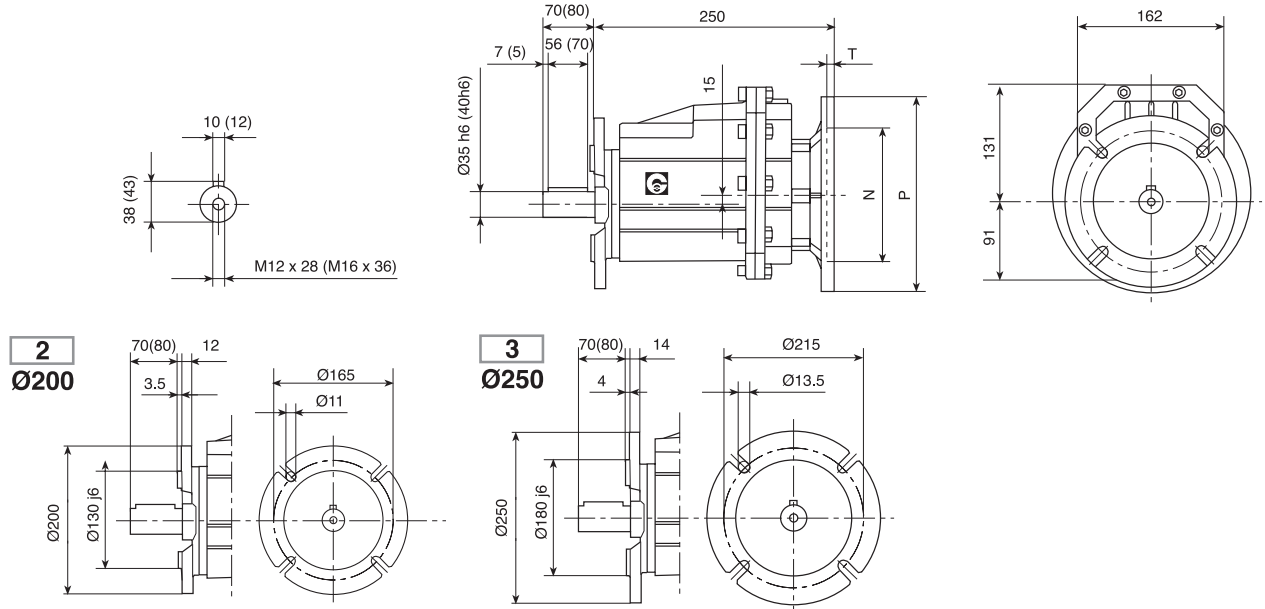

CHC 35 - CHC 40 (IEC)

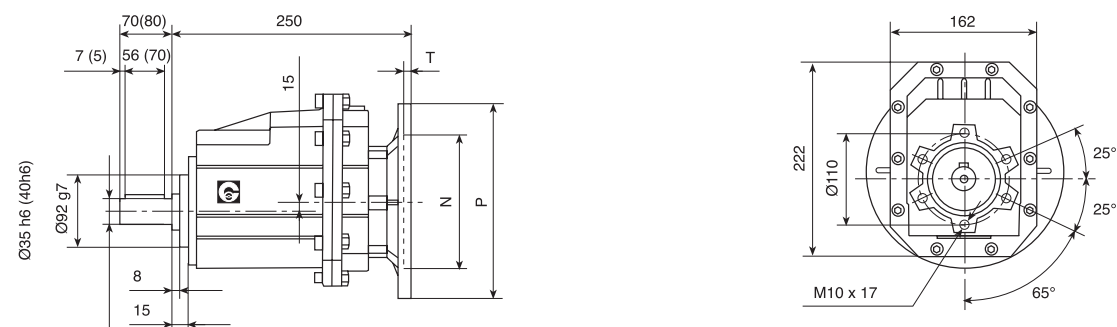

kg. 12,2

Cod. Piede Foot cod.	U	V	V ₁	V ₂	V ₃	W	X	X ₁	Y	Z
B	23.5	130	-	170	-	14	168	205	115	20
C	19.5	149.5	-	180	-	14	185	215	130	20
M	35	110	-	170	185	14	150	230	120	20

IEC	D	F	G	P	M	N	S	T
80B5	19	6	21.8	200	165	130	11	5
80B14	19	6	21.8	120	100	80	7	5
90B5	24	8	27.3	200	165	130	11	5
90B14	24	8	27.3	140	115	95	9	5
100/112B5	28	8	31.3	250	215	180	13.5	5
100/112B14	28	8	31.3	160	130	110	9	5

(...) Tra parentesi misure CHC 40 - Between brackets CHC 40 dimension

ESPLOSO E PARTI DI RICAMBIO EXPLODED DRAWING AND SPARE PARTS LIST

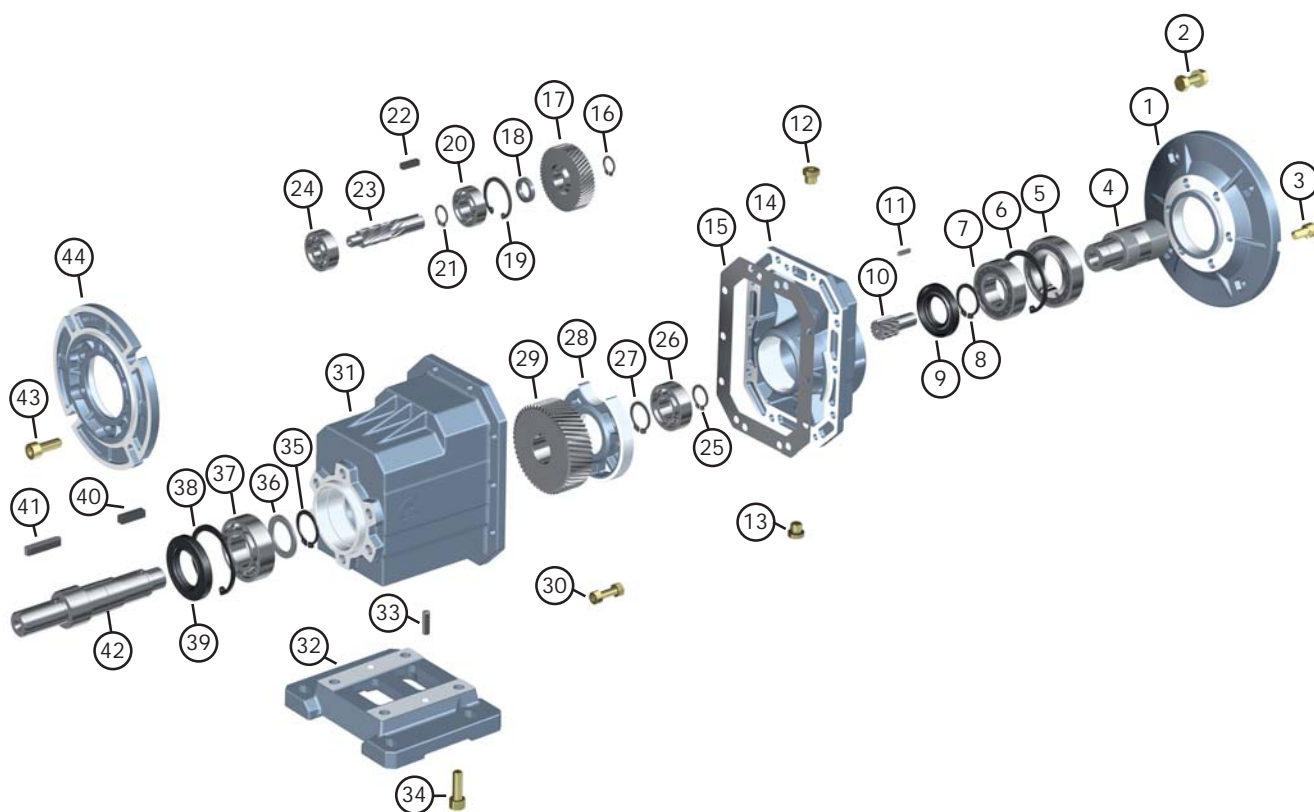

- | | |
|--|---|
| 1 • Flangia attacco motore - <i>Motor connection flange</i> | 23 • Pignone seconda riduzione - <i>Second reduction pinion</i> |
| 2 • Vite con dado - <i>Screw with nut</i> | 24 • Cuscinetto - <i>Bearing</i> |
| 3 • Vite testa esagonale - <i>Hexagonal-head screw</i> | 25 • Seeger - <i>Seeger</i> |
| 4 • Albero entrata cavo - <i>Hole input shaft</i> | 26 • Cuscinetto - <i>Bearing</i> |
| 5 • Cuscinetto - <i>Bearing</i> | 27 • Seeger - <i>Seeger</i> |
| 6 • Seeger - <i>Seeger</i> | 28 • Supporto interno - <i>Internal support</i> |
| 7 • Cuscinetto - <i>Bearing</i> | 29 • Corona seconda riduzione - <i>Second reduction gear</i> |
| 8 • Seeger - <i>Seeger</i> | 30 • Vite con dado - <i>Screw with nut</i> |
| 9 • Anello tenuta - <i>Oil seal</i> | 31 • Cassa - <i>Housing</i> |
| 10 • Pignone prima riduzione - <i>First reduction pinion</i> | 32 • Kit piede - <i>Foot kit</i> |
| 11 • Chiavetta - <i>Key</i> | 33 • Spina di centratura - <i>Dowel pin</i> |
| 12 • Tappo olio - <i>Oil plug</i> | 34 • Vite testa esagonale - <i>Hexagonal-head screw</i> |
| 13 • Tappo olio - <i>Oil plug</i> | 35 • Seeger - <i>Seeger</i> |
| 14 • Coperchio - <i>Cover</i> | 36 • Distanziale - <i>Spacer</i> |
| 15 • Guarnizione - <i>Gasket</i> | 37 • Cuscinetto - <i>Bearing</i> |
| 16 • Seeger - <i>Seeger</i> | 38 • Seeger - <i>Seeger</i> |
| 17 • Corona prima riduzione - <i>First reduction gear</i> | 39 • Anello tenuta - <i>Oil seal</i> |
| 18 • Distanziale - <i>Spacer</i> | 40 • Chiavetta - <i>Key</i> |
| 19 • Seeger - <i>Seeger</i> | 41 • Chiavetta - <i>Key</i> |
| 20 • Cuscinetto - <i>Bearing</i> | 42 • Albero lento - <i>Output shaft</i> |
| 21 • Seeger - <i>Seeger</i> | 43 • Vite testa esagonale - <i>Hexagonal-head screw</i> |
| 22 • Chiavetta - <i>Key</i> | 44 • Flangia uscita - <i>Output flange</i> |



INSTALLAZIONE

- I dati riportati sulla targhetta identificativa devono corrispondere al riduttore ordinato.
- Il livello dell'olio dovrà corrispondere alla quantità prevista per la posizione di montaggio richiesta (vedi catalogo).
- Il fissaggio del riduttore deve avvenire su superfici piane e sufficientemente rigide in modo da evitare qualsiasi vibrazione.
- Il riduttore e l'asse della macchina da movimentare devono essere in perfetto allineamento.
- In caso si prevedano urti, sovraccarichi o blocchi della macchina il cliente dovrà provvedere all'installazione di limitatori, giunti, salvamotori etc.
- Gli accoppiamenti con pignoni, giunti, pulegge ed altri organi devono essere fatti previa pulizia delle parti ed evitando urti nel montaggio poiché questo potrebbe danneggiare i cuscinetti ed altre parti interne.
- Nel caso il motore sia di fornitura del cliente questi dovrà accertarsi che le tolleranze di flangia ed albero corrispondano a questa classe "normale", i nostri motori rispondono a questa esigenza.
- Verificare che le viti di fissaggio del riduttore e dei relativi accessori siano correttamente serrate.
- Adottare gli opportuni accorgimenti per proteggere i gruppi da eventuali agenti atmosferici aggressivi.
- Dove previsto proteggere le parti rotanti da possibili contatti con gli operatori.
- Nel caso i riduttori vengano verniciati proteggere gli anelli di tenuta ed i piani lavorati.
- Tutti i riduttori sono verniciati colore grigio RAL 9022.

FUNZIONAMENTO E RODAGGIO

- Per ottenere le migliori prestazioni è necessario provvedere ad un adeguato rodaggio dei riduttori incrementando la potenza gradualmente nelle prime ore di funzionamento, in questa fase un aumento delle temperature è da considerarsi nella norma.
- In caso di funzionamento difettoso, rumorosità, perdite olio etc. arrestare immediatamente il riduttore e, dove possibile, rimuovere la causa, in alternativa inviare il pezzo alla nostra sede per i controlli.

MANUTENZIONE

- I riduttori ad ingranaggi sono lubrificati con olio sintetico permanente, pertanto non richiedono alcuna manutenzione.

CONSERVAZIONE A MAGAZZINO

- Nel caso di lunga conservazione a magazzino, superiore a tre mesi, si consiglia di proteggere alberi e piani lavorati con antiossidanti e di ingrassare gli anelli di tenuta.

MOVIMENTAZIONE

- Nella movimentazione dei gruppi dovrà essere posta molta attenzione a non danneggiare gli anelli di tenuta ed i piani lavorati.

SMALTIMENTO IMBALLI

- Gli imballi in cui vengono consegnati i nostri riduttori andranno avviati, dove possibile, al riciclo degli stessi tramite le ditte preposte.

INSTALLATION

- *The data shown on the identification name plate must correspond to the gearbox ordered.*
- *The oil level must correspond to the quantity foreseen for the assembly position requested (see catalogue).*
- *All of the other gearboxes are supplied complete with permanent synthetic oil in a quantity that is sufficient for any assembly position.*
- *The gearbox must be fixed on a flat surface that is sufficiently rigid in order to avoid any vibration.*
- *The gearbox and the axis of the machine to be driven must be perfectly aligned or in the event that knocks, overloading or blockage of the machine are foreseen, the client must install a limiting device, joints, overload cut-out etc.*
- *Coupling with pinions, joints, pulleys and other parts must be done after the parts have been cleaned and knocks should be avoided while assembling as they could damage the bearings and other internal parts.*
- *In the event that the motor is supplied by the client, he must check that the flange and shaft tolerances correspond to a "normal" class; our motors satisfy this requirement.*
- *Check that the fixing screws for the gear and the related accessories are correctly tightened.*
- *Take suitable measures to protect the groups from any aggressive atmospheric agents.*
- *Where foreseen, protect rotating parts from any possible contact with the operators.*
- *If the gears are painted, protect the oil seals and the machined surfaces gearboxes.*
- *All of the gears are painted RAL 9022 grey.*

OPERATION AND RUNNING-IN

- *To obtain the best performance the gearboxes must first be run-in by gradually increasing the power in the first few hours of operation, in this phase an increase in temperature is considered normal.*
- *In the event of defective operation, noise, oil leakage, etc. stop the gear immediately and, when possible, remove the cause. Alternatively, send the piece to our factory to be controlled.*

MAINTENANCE

- *The helical gearboxes are lubricated with permanent synthetic oil and therefore do not require any maintenance.*

WAREHOUSE STORAGE

- *If the warehouse storage will be for a long time, more than 3 months, the shafts and machined surfaces should be protected using antioxidants and the oil seals should be greased.*

HANDLING

- *Care must be taken not to damage the oil seals and the machined surfaces when handling the groups.*

DISPOSAL OF PACKAGING

- *The packaging in which our gears are delivered should be sent to specialised companies for recycling if possible.*