

# TL17

series

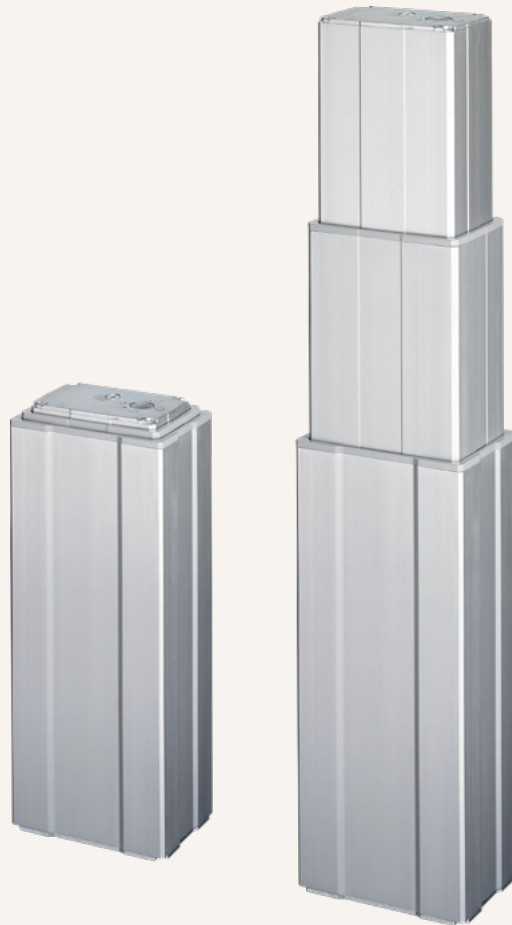

## Product Segments

- **Care Motion**
- **Comfort Motion**
- **Ergo Motion**
- **Industrial Motion**

TiMOTION's TL17 series electric lifting columns are designed specifically for medical applications. Constructed with an extruded aluminum rectangular appearance, our TL17 lift column provides a high degree of stability. This column makes engineering and design processes easier and the system safer by replacing older style lifting mechanisms that have many moving parts and pinch points. The 3 stage, telescopic design provides a greatly reduced retracted height and an increased stroke length.

### General Features

Maximum load	2,000N in push
Maximum dynamic bending moment	250Nm
Maximum static bending moment	500Nm
Maximum speed at full load	22mm/s (with 1,000N in a push condition)
Minimum installation dimension	$\geq \text{Stroke} / 2 + 150\text{mm}$
Dimension of cross section	169.4x121.4mm
Stroke	250~1200mm
Color	Silver, black
Certificate	IEC60601-1, ES60601-1, IEC60601-1-2
Operational temperature range	+5°C~+45°C
IP rating	Up to IPX6
Options	Hall sensor(s)

**Drawing**

Standard Dimensions  
(mm)

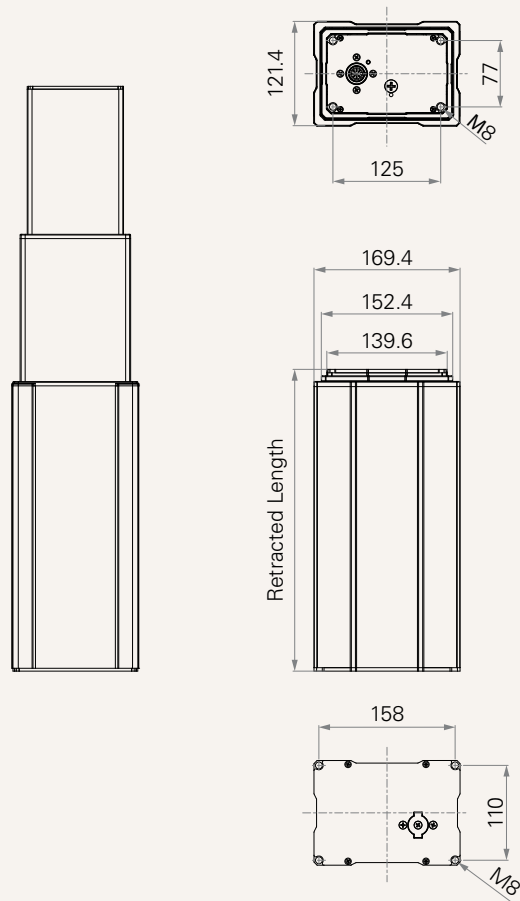

**Load and Speed**

CODE	Load (N)	Bending Moment - X Direction (Nm)		Self Locking Force (N)	Typical Current (A)		Typical Speed (mm/s)	
	Push	Dynamic	Static		No Load 32V DC	With Load 24V DC	No Load 32V DC	With Load 24V DC
<b>Motor Speed (2800RPM)</b>								
<b>B</b>	2000	250	500	2000	2.5	4.3	21.5	10.5
<b>C</b>	1000	250	500	1000	2.5	4.3	41.0	22.0
<b>D</b>	1500	250	500	1200	2.5	4.5	34.5	16.0

**Note**

- 1 The current & speed in table are tested with 24V DC motor. With a 12V DC motor, the current is approximately twice the current measured in 24V DC; speed will be similar for both voltages.
- 2 The current & speed in table are tested when the actuator is extending under push load.
- 3 The current & speed in table and diagram are tested with TiMOTION control boxes, and there will be around 10% tolerance depending on different models of the control box.  
(Under no load condition, the voltage is around 32V DC. At rated load, the voltage output will be around 24V DC)
- 4 Bending moment Y direction = X\*0.8

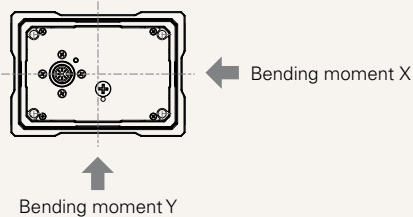

Performance Data (24V DC Motor)

Motor Speed (2800RPM)

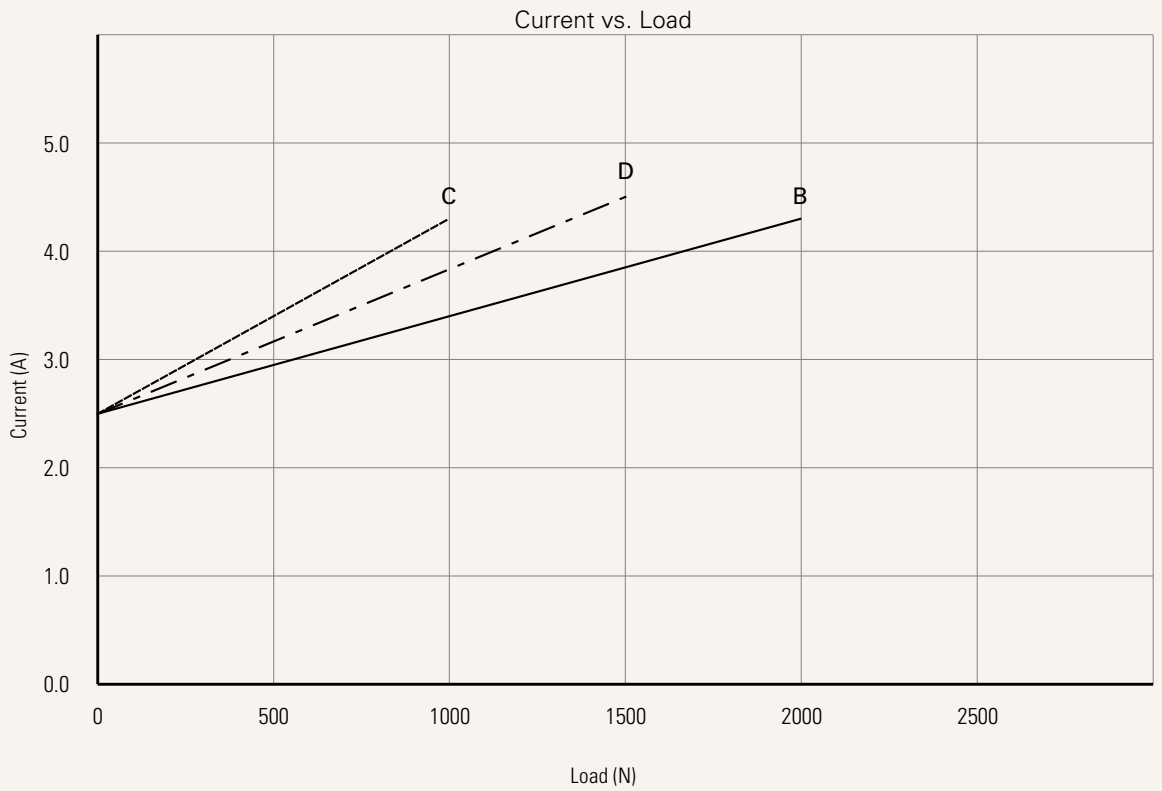

<b>Voltage</b>	1 = 12V DC	5 = 24V DC, PTC
<b>Load and Speed</b>	<a href="#">See page 2</a>	
<b>Stroke (mm)</b>	250-1200	
<b>Retracted Length (mm)</b>	Minimum retract length needs to $\geq (\text{stroke} / 2) + 150$	
<b>Cable Exit</b> <a href="#">See page 8</a>	1 = Top end socket	
<b>Special Functions for Spindle Sub-Assembly</b>	0 = Without (standard)	1 = Safety nut
<b>Functions for Limit Switches</b> <a href="#">See page 8</a>	1 = Two switches at full retracted / extended positions to cut current 3 = Two switches at full retracted / extended positions to send signal	
<b>IP Rating</b>	1 = Without	2 = IPX4 3 = IPX6
<b>Output Signals</b>	0 = Without	2 = Hall sensor*2
<b>Connector</b> <a href="#">See page 9</a>	1 = DIN 6P, socket	
<b>Cable Length (mm)</b>	0 = Without (the corresponding extension cable TEC needs to be ordered separately)	
<b>Color</b>	1 = Black	2 = Matte silver
<b>Tubes Direction</b> <a href="#">See page 10</a>	0 = Thinner on top	1 = Wider on top
<b>Grounding Function</b>	0 = Without	1 = With

### Note

1 TL17 is designed especially for push applications, not suitable for pull applications.

# TL17 Ordering Key - Side Cable

TL17

Version: 20190222-1

<b>Voltage</b>	1 = 12V DC	5 = 24V DC, PTC		
<b>Load and Speed</b>	<a href="#">See page 2</a>			
<b>Stroke (mm)</b>	250-1200			
<b>Retracted Length (mm)</b>	<a href="#">See page 7</a>			
<b>Cable Exit</b> <a href="#">See page 8</a>	2 = Bottom side cable	3 = Top side cable		
<b>Special Functions for Spindle Sub-Assembly</b>	0 = Without (standard)	1 = Safety nut		
<b>Functions for Limit Switches</b> <a href="#">See page 8</a>	1 = Two switches at full retracted / extended positions to cut current 3 = Two switches at full retracted / extended positions to send signal			
<b>IP Rating</b>	1 = Without	2 = IPX4	3 = IPX6	
<b>Output Signals</b>	0 = Without	2 = Hall sensor*2		
<b>Connector</b> <a href="#">See page 9</a>	1 = DIN 6P, 90° plug	2 = Tinned leads	F = DIN 6P, 180° plug	
<b>Cable Length (mm)</b>	1 = Straight, 500 2 = Straight, 750	3 = Straight, 1000 4 = Straight, 1250	5 = Straight, 1500 6 = Straight, 1750	7 = Straight, 2000
<b>Color</b>	1 = Black (Black cable set) 2 = Matte silver (428C color cable set)		3 = Matte silver (Black cable set)	
<b>Tubes Direction</b> <a href="#">See page 10</a>	0 = Thinner on top	1 = Wider on top		
<b>Grounding Function</b>	0 = Without	1 = With		

## Note

1 TL17 is designed especially for push applications, not suitable for pull applications.

<b>Voltage</b>	1 = 12V DC	5 = 24V DC, PTC
<b>Load and Speed</b>	<a href="#">See page 2</a>	
<b>Stroke (mm)</b>	250-1200	
<b>Retracted Length (mm)</b>	<a href="#">See page 7</a>	
<b>Cable Exit</b> <a href="#">See page 8</a>	B = Top side- for TH; Bottom side- for TP C = Bottom side- Y cable, for TH + TP D = Top side- for the 2nd column; Bottom side- for TH & TP; direct cut operation with 2 columns E = Top side- for the 2nd column & TH; Bottom side- for TP; direct cut operation with 2 columns	
<b>Special Functions for Spindle Sub-Assembly</b>	0 = Without (standard)	1 = Safety nut
<b>Functions for Limit Switches</b> <a href="#">See page 8</a>	1 = Two switches at full retracted / extended positions to cut current	
<b>IP Rating</b>	1 = Without	2 = IPX4      3 = IPX6
<b>Output Signals</b>	0 = Without	
<b>Connector</b> <a href="#">See page 9</a>	1 = DIN 6P, socket	
<b>Cable Length (mm)</b> <a href="#">See page 9</a>	B = Cable exit #B, 2=L3=100 C = Cable exit #C, L1=L2=L3=100 D = Cable exit #D, L2=L3=L4=100 E = Cable exit #E, L2=L3=L4=100	
<b>Color</b>	1 = Black (Black cable set) 2 = Matte silver (428C color cable set)	3 = Matte silver (Black cable set)
<b>Tubes Direction</b> <a href="#">See page 10</a>	0 = Thinner on top	1 = Wider on top
<b>Grounding Function</b>	0 = Without	1 = With

### Note

1 TL17 is designed especially for push applications, not suitable for pull applications.

## Retracted Length (mm)

1. Retracted length needs to  $\geq$  Stroke+Y

A. Load (N)	2000	1000	1500
	(S/2)+150		

### Note

1 Different retracted length is relative to different bending moment, [See page 2.](#)

## B. Cable Exit

CODE	Top End Socket	Bottom Side Cable	Top Side Cable	Direct Cut	
	1	2	3	B, D, E	C
B	-	+20	+15	+35	+20

## Functions for Limit Switches

### Wire Definitions

CODE	Pin					
	1 (Green)	2 (Red)	3 (White)	4 (Black)	5 (Yellow)	6 (Blue)
1	extend (VDC+)	N/A	N/A	N/A	retract (VDC+)	N/A
3	extend (VDC+)	common	upper limit switch	N/A	retract (VDC+)	lower limit switch

## Cable Exit

1 = Top end socket

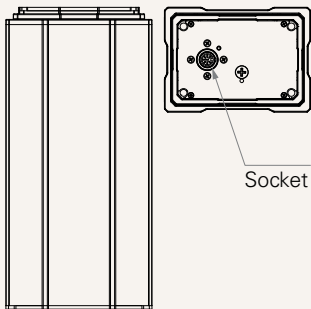

2 = Bottom side cable

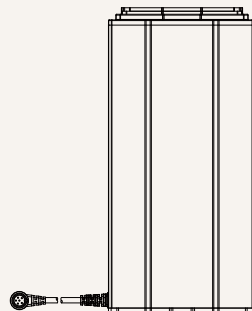

3 = Top side cable

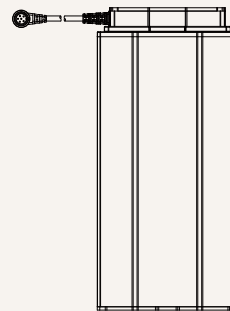

B = Top side- for TH; Bottom side- for TP

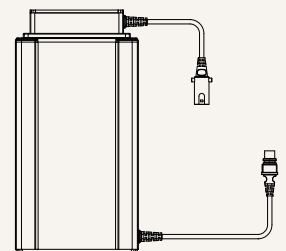

C = Bottom side- Y cable, for TH + TP

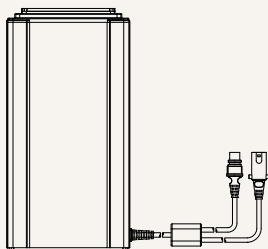

D = Top side- for the 2nd column; Bottom side- for TH & TP; direct operation with 2 columns

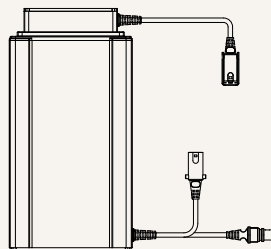

E = Top side- for the 2nd column & TH; Bottom side- for TP; direct cut operation with 2 columns

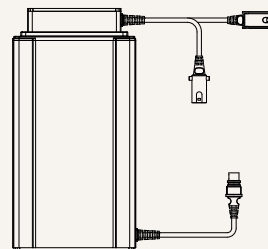



## Connector

1 = DIN 6P, socket

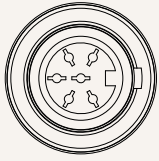

2 = Tinned leads

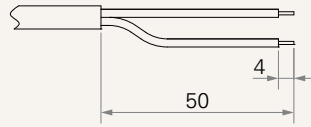

F = DIN 6P, 180° plug

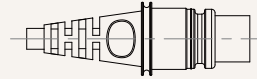

C = Direct cut, water proof, anti-pull

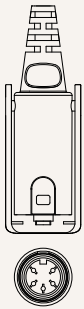

For TH:  
long DIN 5P (Pin array 240°),  
180° socket (with anti-pull clip)



For TP:  
long DIN 5P (Pin array 240°),  
180° plug (with O-ring)

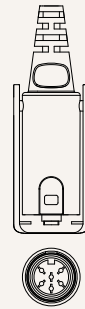

For Column 2:  
long DIN 6P (Pin array 240°),  
180° plug (with anti-pull clip)

## Cable Length (mm)

B = Cable exit #B, L2 = L3 = 100

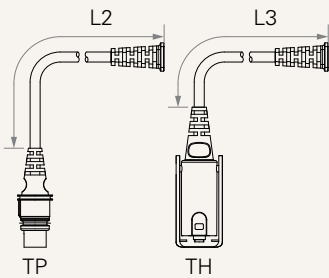

C = Cable exit #C, L1 = L2 = L3 = 100

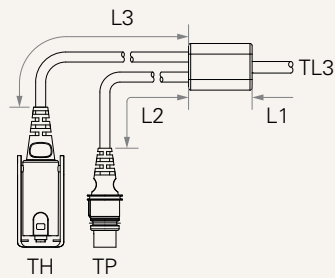

D, E = Cable exit #D, #E, L2 = L3 = L4 = 100

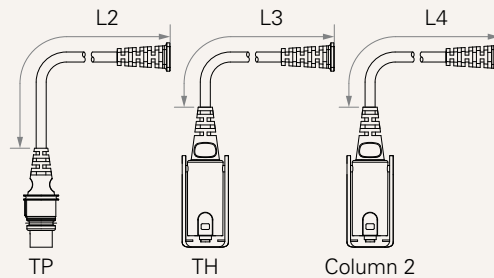

---

## Tubes Direction

0 = Thinner on top

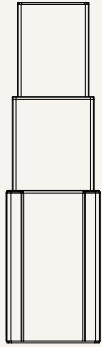

1 = Wider on top

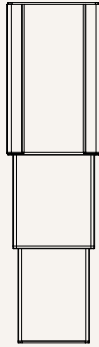

---

## Terms of Use

The user is responsible for determining the suitability of TiMOTION products for a specific application. TiMOTION products are subject to change without prior notice.