

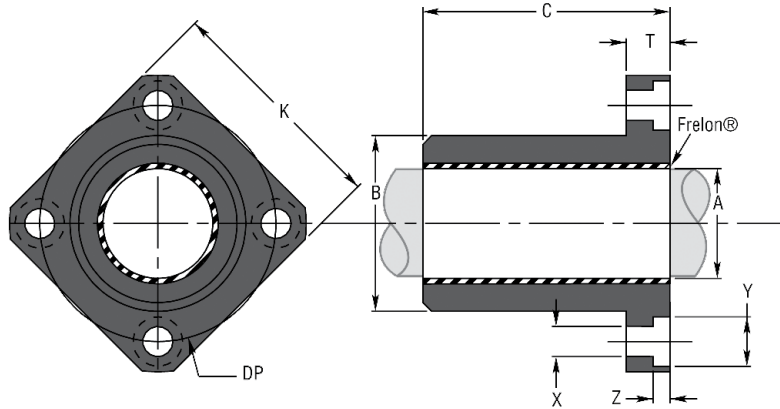

TIP SFPM / SFPMC
 SFPM / SFPMC TYPE



Cod Code	Tip Type	A		B h7	C	DF	DP	K	T	X	Y	Z	Sarcină Load C0	Greutate Weight
		min	max											
(mm)														
SFPM - seria de precizie / precision series														
84.029.003	SFPM 8	8,013	8,035	16	25	32	24	25	8	3,5	6	3,1	4316	18
84.029.005	SFPM 12	12,016	12,043	22	32	42	32	32	9	4,5	7,5	4,1	8280	37
84.029.007	SFPM 16	16,016	16,043	26	36	46	36	35	9	4,5	7,5	4,1	12429	47
84.029.009	SFPM 20	20,020	20,053	32	45	54	43	42	11	5,5	9	5,1	19414	85
84.029.011	SFPM 25	25,020	25,053	40	58	62	51	50	11	5,5	9	5,1	31284	156
84.029.013	SFPM 30	30,020	30,053	47	68	76	62	60	14	6,6	11	6,1	44008	257
84.029.015	SFPM 40	40,250	40,064	62	80	98	80	75	18	9	14	8,1	69033	500
84.029.016	SFPM 50	55,025	50,064	75	100	112	94	88	18	9	14	8,1	107871	825
84.029.017	SFPM 60	60,030	60,076	90	125	134	112	106	24	11	17	11,1	161796	1506
SFPM C - seria compensată / compensated series														
84.052.003	SFPM 8C	8,063	8,085	16	25	32	24	25	8	3,5	6	3,1	4316	18
84.052.005	SFPM 12C	12,066	12,093	22	32	42	32	32	9	4,5	7,5	4,1	8280	37
84.052.007	SFPM 16C	16,066	16,093	26	36	46	36	35	9	4,5	7,5	4,1	12429	47
84.052.009	SFPM 20C	20,096	20,129	32	45	54	43	42	11	5,5	9	5,1	19414	85
84.052.011	SFPM 25C	25,096	25,129	40	58	62	51	50	11	5,5	9	5,1	31284	156
84.052.013	SFPM 30C	30,096	30,129	47	68	76	62	60	14	6,6	11	6,1	44008	257
84.052.015	SFPM 40C	40,127	40,166	62	80	98	80	75	18	9	14	8,1	69033	500
84.052.016	SFPM 50C	50,127	50,166	75	100	112	94	88	18	9	14	8,1	107871	825
84.052.017	SFPM 60C	60,182	60,228	90	125	134	112	106	24	11	17	11,1	161796	1506

Material: aluminiu anodizat
 Acoperire interioară: Frelon Gold

Material: anodized aluminium
 Internal coating: Frelon Gold