

UNI-GUIDE™ TIP UGA
UNI-GUIDE™ UGA TYPE

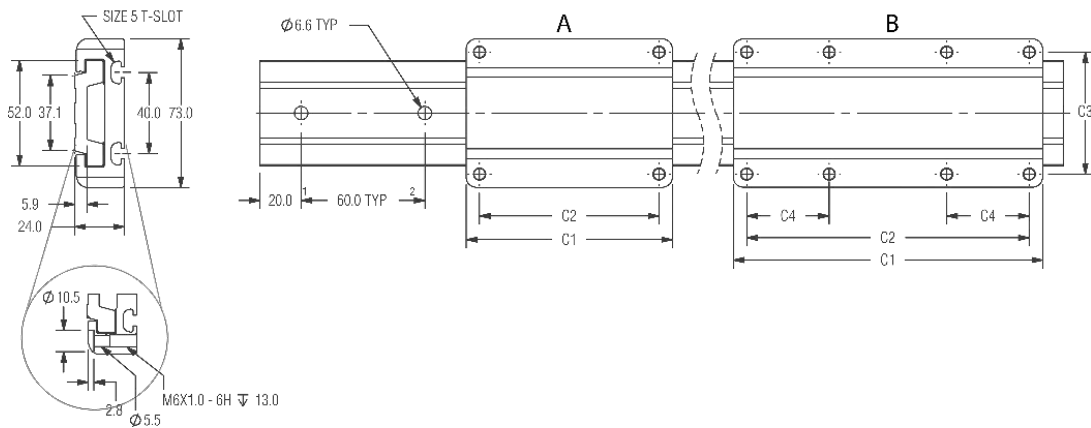

Șină Rail	Cod Code		Tip Type		Sanie tip „A” “A” type of block				Sanie tip „B” “B” type of block				Fz max	FY	MY	MX	MZ	Viteza max. Max speed	
	Precizie Precision	Compensat Compensated	Precizie Precision	Compensat Compensated	C1	C2	C3	C4	C1	C2	C3	C4							
					(mm)								(N)		(Nm)		(m/s)		
83.030.001	83.031.001	83.031.004	UGA040C-0P1G	UGA040C-0C1G	100	87	60	-	-	-	-	-	-	8200	4900	170	120	170	1,524
	83.031.002	83.031.005	UGA040C-1P1G	UGA040C-1C1G	-	-	-	-	150	137	60	40	6600	5700	290	120	290		
	83.031.003	83.031.006	UGA040C-2P1G	UGA040C-2C1G	-	-	-	-	200	187	60	60	4900	6100	290	120	290		

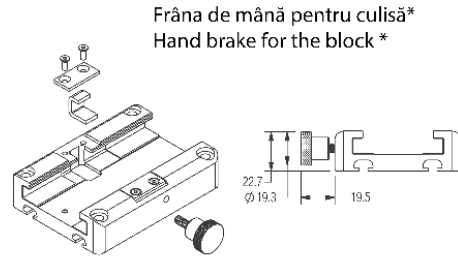
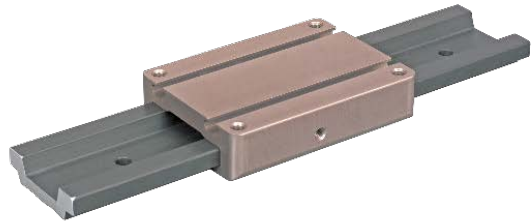
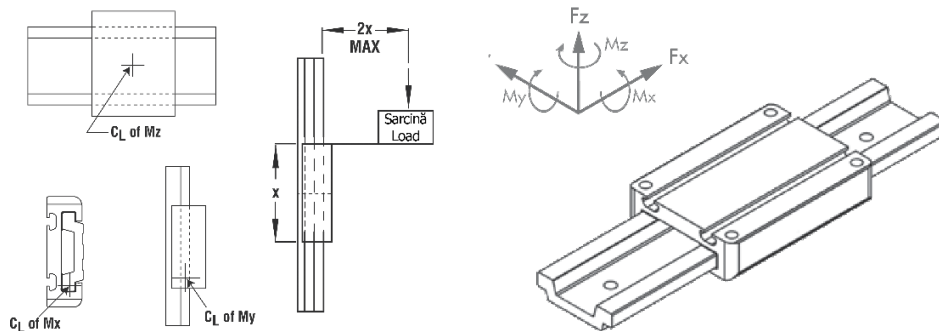

Tip Type	Fz		Fy	Mx	Mz	My
	Compresiune Compressive	Tracțiune Tensile				
	(N)		(Nm)			
UGA040C-0...1G	8200	2700	4900	120	170	170
UGA040C-1...1G	6600	2700	5700	120	290	290
UGA040C-2...1G	4900	2700	6100	120	290	290