

TIP M
 M TYPE

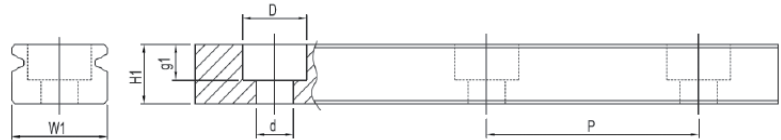

Cod Code	Tip Type	W1	H1	P	D	d	g1	Lungime max. Max. length	Greutate Weight
83.058.001	M7-N	7	5	15	4,2	2,4	2,3	990	0,253
83.058.002	M9-N	9	6	20	6	3,5	3,5	1000	0,391
83.058.003	M12-N	12	8	25	6,5	3,5	4,5	1000	0,679
83.058.004	M15-N	15	10	40	6,5	3,5	4,5	1000	1,071

N: precizie standard standard accuracy
Material: oțel inoxidabil Material: stainless steel

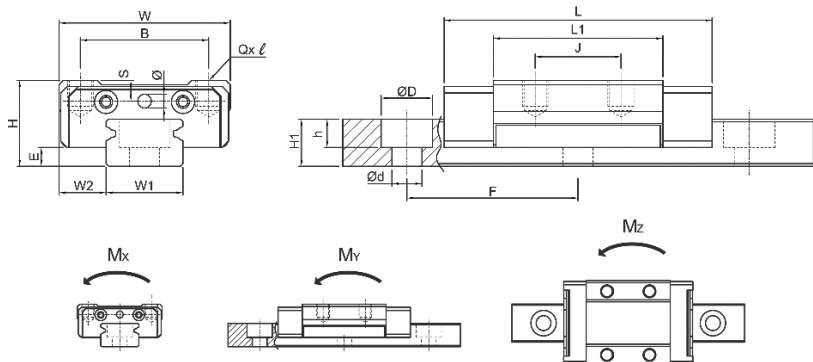

Cod Code	Tip Type	Dimensiuni / Sizes										Sarcină Load		Moment static Static moment			Greutate Weight
		H	W2	E	W	B	J	L	L1	Qx1	Ø	C	Co	Mx	My	Mz	
N-G1		(mm)										(kN)		(kNm)			
83.057.001	M07N	8	5	1,5	17	12	8	24,3	14,1	M2x2,5	-	1,197	1,703	0,006	0,004	0,004	0,009
83.057.002	M07L	8	5	1,5	17	12	13	31,8	21,6	M2x2,5	-	1,631	2,65	0,01	0,010	0,010	0,012
83.057.003	M09N	10	5,5	2	20	15	10	31,3	20,7	M3x3	-	1,721	2,545	0,012	0,009	0,009	0,017
83.057.004	M09L	10	5,5	2	20	15	16	41,4	30,8	M3x3	-	2,375	4,03	0,019	0,022	0,022	0,025
83.057.005	M12N	13	7,5	3	27	20	15	34,9	21,3	M3x3,5	-	3,023	3,816	0,024	0,014	0,014	0,032
83.057.006	M12L	13	7,5	3	27	20	20	45,4	31,8	M3x3,5	-	4,246	6,2	0,038	0,035	0,035	0,046
83.057.009	M15N	16	8,5	4	32	25	20	44,4	27,7	M3x4	-	4,54	5,842	0,045	0,029	0,029	0,058
83.057.008	M15L	16	8,5	4	32	25	25	59,4	42,7	M3x4	-	6,492	9,737	0,075	0,074	0,074	0,086

N-G1: precizie standard cu preîncărcare ușoară standard accuracy with light preload
Material: oțel inoxidabil Material: stainless steel