

# M129



PA6  
+GF

UL94  
HB



## REVOLVING HANDLE WITH HEXAGON SOCKET HEAD SCREW

### Material:

Reinforced polyamide.  
Oils and greases resistant.

### Surface:

Satin.

### Colour:

Black (RAL 9011).

### Revolving Insert:

Revolving zinc-plated steel threaded stud, with hexagon socket head and brass rotative ring. (thread tolerance 6g).

### SPECIAL REQUEST:

- It is possible to supply colours as shown in the table at pag. M-27, on request and for quantities.

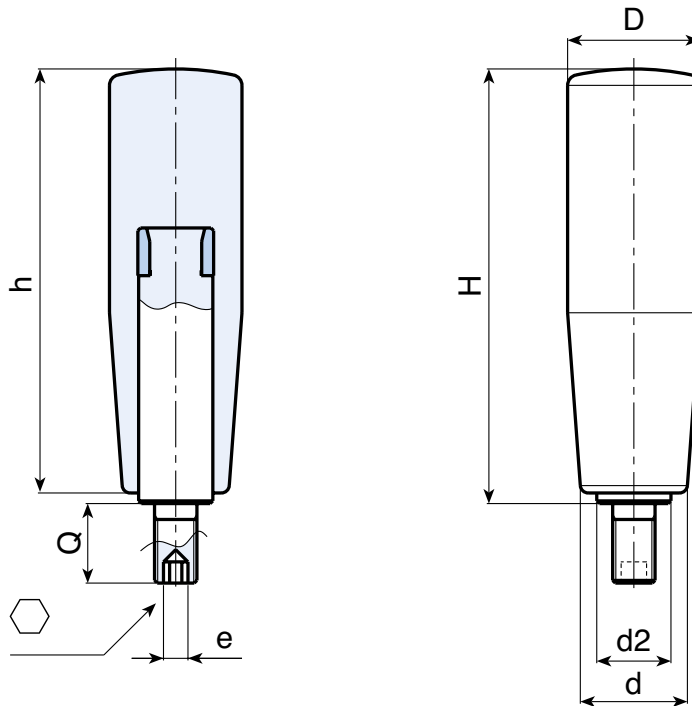

	art.	H	D	h	d	d2	e	d1 6g	Q	g
●	M12950.TM06X1201	51,5	20	50	15	10	○ 3	M06	12	42
●	M12960.TM06X1201	61,5	23	60	18	10	○ 3	M06	12	54
●	M12960.TM08X1501	61,5	23	60	18	10	○ 4	M08	15	60
●	M12970.TM08X1501	71,5	25	70	19	10	○ 4	M08	15	92
●	M12970.TM10X1501	71,5	25	70	19	10	○ 4	M10	15	94
●	M12980.TM08X1501	81,5	26	80	21	14	○ 4	M08	15	98
●	M12980.TM10X1501	81,5	26	80	21	14	○ 5	M10	15	104
●	M12980.TM12X1501	81,5	26	80	21	14	○ 5	M12	15	104
●	M12990.TM10X1501	91,5	27	90	22	14	○ 5	M10	15	118
●	M12990.TM12X1501	91,5	27	90	22	14	○ 5	M12	15	120