

## ELEMENTE DE STRÂNGERE PENTRU GHIDAJ PROFILAT CLAMPING ELEMENTS FOR PROFILE GUIDE

TIPUL FRCMANLT (MANUAL)  
FRCMANLT TYPE (MANUAL)

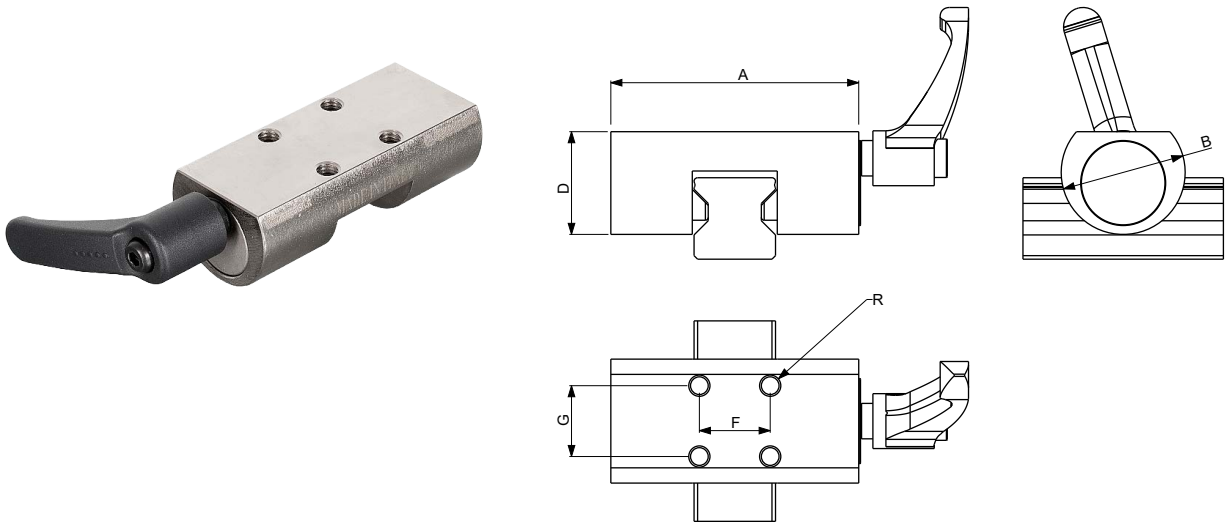

Cod Code	Tipul de bloc TBI MOTION TBI MOTION block type	Forța de strângere Clamping force	A	B	D	F	G	R
83.103.060	TRH15FN; FL	1200	47	25	17,5+3*	17	17	M4x5
83.103.061	TRH15VN; VL	1200	47	25	17,5+7*	17	17	M4x5
83.103.071	TRS15VS; VN; FS; FN	1200	47	25	17,5+3*	17	17	M4x5
83.103.062	TRH20VN; VL; VE; FN; FL; FE	1200	60	26	20+4*	15	15	M5X6
83.103.072	TRS20VS; VN; FS; FN	1200	60	26	20+2*	15	15	M5X6
83.103.064	TRH25FN; FL; FE	1200	70	32	24+5*	20	20	M6x7
83.103.063	TRH25VN; VL; VE	1200	70	32	24+8*	20	20	M6x7
83.103.073	TRS25VS; VS; VN	1200	70	32	24+2*	20	20	M6x7
83.103.066	TRH30FN; FL; FE	2000	90	38	29+3*	22	22	M6x8
83.103.065	TRH30VN; VL; VE	2000	90	38	29+6*	22	22	M6x8
83.103.074	TRS30VS; VN; VL	2000	90	38	29+3*	22	22	M6x8
83.103.068	TRH35FN; FL; FE	2000	98	42	32+6*	24	24	M8x10
83.103.067	TRH35VN; VL; VE	2000	98	42	32+12*	24	24	M8x10
83.103.075	TRS35VS; VN; VE	2000	98	42	32+6*	24	24	M8x10
83.103.070	TRH45FL; FE	2000	118	50	42+6*	26	26	M10x14
83.103.069	TRH45VL; VE	2000	118	50	42+16*	26	26	M10x14
83.103.076	TRS45VN	2000	118	50	42+6*	26	26	M10x14
PENTRU BOSCH REXROTH, TIPUL SCHNEEBERGER / FOR BOSCH REXROTH, SCHNEEBERGER TYPE								
FRCMAN15S	S	1200	47	25	19	17	17	M4x5
FRCMAN20S	S	1200	60	28	23	15	15	M5X6
FRCMAN25S	S	1200	70	35	29	20	20	M6x7
FRCMAN30S	S	2000	90	40	32	22	22	M6x8
FRCMAN35S	S	2000	98	45	37	24	24	M8x10

\* - După semnul + înseamnă grosimea distanțierului. Pentru alte produse, valoarea „D” poate fi diferită. After the sign + means the spacer thickness. For other products the value “D” maybe different.