

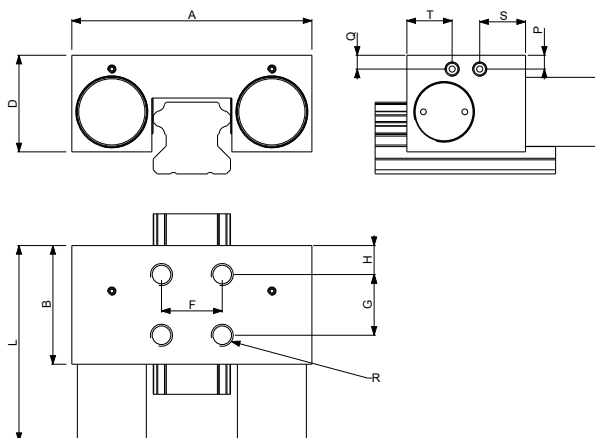

TIPUL FRC (PNEUMATIC)
FRC TYPE (PNEUMATIC)

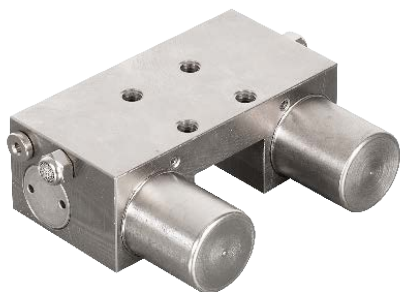

Cod Code				Tipul de bloc TBI MOTION TBI MOTION block type	Forța de strângere (N) Clamping force (N)				A	B	D	F	G	H	L	P	Q	R	S	T
SEM	SE	DE	DEM		SEM	SE	DE	DEM	(mm)											
83.103.041	83.103.112	83.103.129	83.103.146	TRH15FN; FL	400	650	650	1050	60	43	21,5	15	15	12,5	62	5,5	15,5	M4x5	37	6
83.103.042	83.103.113	83.103.130	83.103.147	TRH15VN; VL	400	650	650	1050	60	43	21,5+5*	15	15	12,5	62	5,5	15,5	M4x5	37	6
83.103.052	83.103.114	83.103.131	83.103.148	TRS15VS; VN; FS; FN	400	650	650	1050	60	43	21,5	15	15	12,5	62	5,5	15,5	M4x5	37	6
83.103.043	83.103.115	83.103.132	83.103.149	TRH20VN; VL; VE; FN; FL; FE	600	1000	1000	1600	70	39	25,5	20	20	14	61	5	5	M5x5	18,5	5
83.103.054	83.103.116	83.103.133	83.103.150	TRS20VS; VN; FS; FN	600	1000	1000	1600	70	39	25,5	20	20	14	61	5	5	M5x5	18,5	5
83.103.045	83.103.117	83.103.134	83.103.151	TRH25FN; FL; FE	750	1200	1200	1950	77	39	28+2*	20	20	14	63,5	5	6	M6x8	19	5,5
83.103.044	83.103.118	83.103.135	83.103.152	TRH25VN; VL; VE	750	1200	1200	1950	77	39	28+6*	20	20	14	63,5	5	6	M6x8	19	5,5
83.103.055	83.103.119	83.103.136	83.103.153	TRS25VS; VN; FN	750	1200	1200	1950	77	39	28	20	20	14	63,5	5	6	M6x8	19	5,5
83.103.047	83.103.120	83.103.137	83.103.154	TRH30FN; FL; FE	1050	1750	1750	2800	87	43	35+2*	22	22	10,5	71	5	5	M8x8	16,5	16,5
83.103.046	83.103.121	83.103.138	83.103.155	TRH30VN; VL; VE	1050	1750	1750	2800	87	43	35+5*	22	22	10,5	71	5	5	M8x8	16,5	16,5
83.103.057	83.103.122	83.103.139	83.103.156	TRS30VS; VN; VL	1050	1750	1750	2800	87	43	35+2*	22	22	10,5	71	5	5	M8x8	16,5	16,5
83.103.049	83.103.123	83.103.140	83.103.157	TRH35FN; FL; FE	1250	2000	2000	3250	106	46	42,5	24	24	7,5	78	11	11	M8x15	23	7
83.103.048	83.103.124	83.103.141	83.103.158	TRH35VN; VL; VE	1250	2000	2000	3250	106	46	42,5+8*	24	24	7,5	78	11	11	M8x15	23	7
83.103.058	83.103.125	83.103.142	83.103.159	TRS35VS; VN; VE	1250	2000	2000	3250	106	46	42,5	24	24	7,5	78	11	11	M8x15	23	7
83.103.051	83.103.126	83.103.143	83.103.160	TRH45FL; FE	1500	2300	2300	3800	120	50	52	26	26	12	82	15	8	M10x19	20	20
83.103.050	83.103.127	83.103.144	83.103.161	TRH45VL; VE	1500	2300	2300	3800	120	50	52+12*	26	26	12	82	15	8	M10x19	20	20
83.103.059	83.103.128	83.103.145	83.103.162	TRS45VN	1500	2300	2300	3800	120	50	52	26	26	12	82	15	8	M10x19	20	20
PENTRU BOSCH REXROTH, TIPUL SCHNEEBERGER / FOR BOSCH REXROTH, SCHNEEBERGER TYPE																				
FRC15-SEM	FRC15-SE	FRC15-DE	FRC15-DEM	S	400	650	650	1050	57	43	20,8	15	15	12,5	62	5	15	M4x5	37	6
FRC20-SEM	FRC20-SE	FRC20-DE	FRC20-DEM	S	600	1000	1000	1600	68	39	27	20	20	14	61	5	7	M5x5	16,9	5,5
FRC25S-SEM	FRC25S-SE	FRC25S-DE	FRC25S-DEM	S	750	1200	1200	1950	75	39	32,5	20	20	14	63,5	6,6	9,5	M6x8	19,5	5,5
FRC30S-SEM	FRC30S-SE	FRC30S-DE	FRC30S-DEM	S	1050	1750	1750	2800	87	43	38,5	22	22	10,5	71	8,5	8,5	M8x8	16,5	16,5
FRC35S-SEM	FRC35S-SE	FRC35S-DE	FRC35S-DEM	S	1250	2000	2000	3250	106	46	42,5	24	24	7,5	78	11	11	M8x15	23	7
FRC45S-SEM	FRC45S-SE	FRC45S-DE	FRC45S-DEM	S	1500	2300	2300	3800	116	50	52	26	26	12	82	15	8	M10x19	20	20

* - După semnul + înseamnă grosimea distanțierului. Pentru alte produse, valoarea „D” poate fi diferită.

SEM - de obicei închisă, presiunea aerului pentru a se deschide

SE - de obicei deschisă, presiunea aerului pentru a se închide

DE - de obicei deschisă, presiunea aerului pentru a se închide și a se deschide

DEM - de obicei închisă, presiunea aerului pentru a se închide și a se deschide

After the sign + means the spacer thickness. For other products the value “D” maybe different.

normally closed, air to open

normally open, air to close

normally open, air to close and to open

normally closed, air to close and to open