

TIP DFPM / DFPMC DFPM / DFPMC TYPE

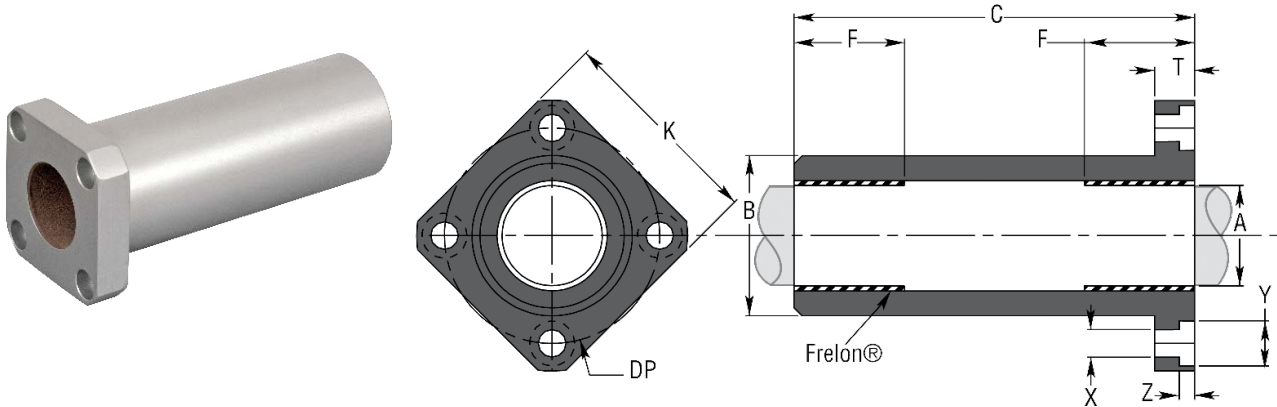

Cod Code	Tip Type	A		B h7	C	DF	DP	K	F	T	X	Y	Z	Sarcină Load C0 (N)	Greutate Weight (g)
		min	max												
DFPM - seria de precizie / precision series															
84.045.003	DFPM 8	8,013	8,035	16	45	32	24	25	12,1	8	3,5	6	3,1	4179	27
84.045.005	DFPM 12	12,016	12,043	22	57	42	32	32	15,4	9	4,5	7,5	4,1	7976	55
84.045.007	DFPM 16	16,016	16,043	26	70	46	36	35	20,4	9	4,5	7,5	4,1	14087	78
84.045.009	DFPM 20	20,020	20,053	32	80	54	43	42	22,1	11	5,5	9	5,1	19071	133
84.045.011	DFPM 25	25,020	25,053	40	112	62	51	50	33,1	11	5,5	9	5,1	35708	270
84.045.013	DFPM 30	30,020	30,053	47	123	76	62	60	35	14	6,6	11	6,1	45303	413
84.045.015	DFPM 40	40,250	40,064	62	151	98	80	75	44	18	9	14	8,1	75939	846
84.045.016	DFPM 50	55,025	50,064	75	192	112	94	88	69,5	18	9	14	8,1	149936	1450
84.045.017	DFPM 60	60,030	60,076	90	209	134	112	106	73	24	11	17	11,1	188980	2329
DFPM C - seria compensată / compensated series															
84.053.003	DFPM 8C	8,063	8,085	16	45	32	24	25	12,1	8	3,5	6	3,1	4179	27
84.053.005	DFPM 12C	12,066	12,093	22	57	42	32	32	15,4	9	4,5	7,5	4,1	7976	55
84.053.007	DFPM 16C	16,066	16,093	26	70	46	36	35	20,4	9	4,5	7,5	4,1	14087	78
84.053.009	DFPM 20C	20,096	20,129	32	80	54	43	42	22,1	11	5,5	9	5,1	19071	133
84.053.011	DFPM 25C	25,096	25,129	40	112	62	51	50	33,1	11	5,5	9	5,1	35708	270
84.053.013	DFPM 30C	30,096	30,129	47	123	76	62	60	35	14	6,6	11	6,1	45303	413
84.053.015	DFPM 40C	40,127	40,166	62	151	98	80	75	44	18	9	14	8,1	75939	846
84.053.016	DFPM 50C	50,127	50,166	75	192	112	94	88	69,5	18	9	14	8,1	149936	1450
84.053.017	DFPM 60C	60,182	60,228	90	209	134	112	106	73	24	11	17	11,1	188980	2329

Material: aluminiu anodizat **Material:** anodized aluminium
Acoperire interioară: Frelon Gold **Internal coating:** Frelon Gold