

# B320



## HANDLE WITH TUBE D. 20

### Materials

#### Plastic End Bracket:

Reinforced polyamide. Oils and greases resistant.

#### Tube:

Aluminum alloy 6060.

### Surfaces:

#### Plastic End Bracket:

Satin. Colour Black (RAL 9011).

#### Tube:

Smooth. Silver anodised.

### Hole:

Smooth right through hole obtained by moulding the plastic.



### SPECIAL REQUEST:

- It is possible to supply the handle with different lengths on request and for quantities.
- It is possible to provide screw cover plugs on request.
- It is possible to supply colours as shown in the table at pag. B-37, on request and for quantities.

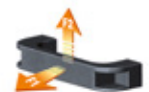
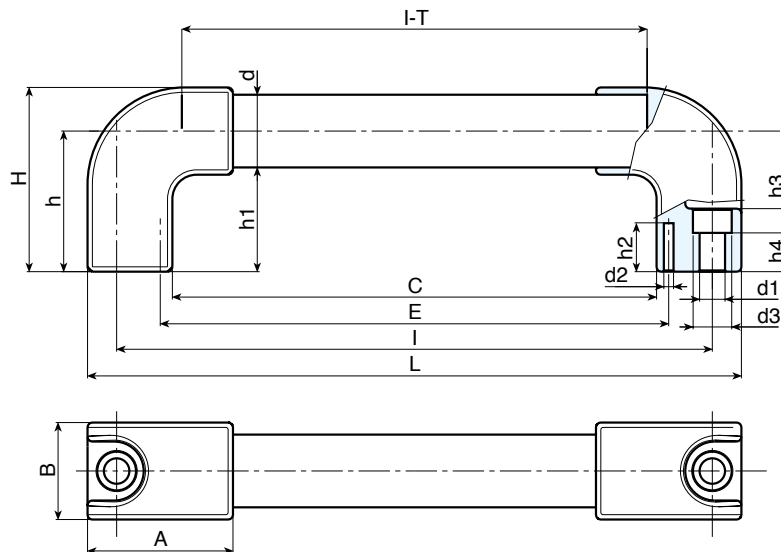

Art.	L	I	C	E	A	B	T	H	h	h1	h4	h3	h2	d	d1	d3	d2	g	F1 (N)	F2 (N)
● B320200.TG2001	220	200	162	174	50	30	45	57	43	33	7	12,5	15	20	8,5	14,5	4	130	2400	1850
● B320250.TG2001	270	250	212	224	50	30	45	57	43	33	7	12,5	15	20	8,5	14,5	4	145	1800	1450
● B320300.TG2001	320	300	262	274	50	30	45	57	43	33	7	12,5	15	20	8,5	14,5	4	155	1500	1500
● B320350.TG2001	370	350	312	324	50	30	45	57	43	33	7	12,5	15	20	8,5	14,5	4	165	1500	1250
● B320400.TG2001	420	400	362	374	50	30	45	57	43	33	7	12,5	15	20	8,5	14,5	4	176	1400	850
● B320500.TG2001	520	500	462	474	50	30	45	57	43	33	7	12,5	15	20	8,5	14,5	4	200	1000	800
● B320600.TG2001	620	600	562	574	50	30	45	57	43	33	7	12,5	15	20	8,5	14,5	4	225	900	750
● B320700.TG2001	720	700	662	674	50	30	45	57	43	33	7	12,5	15	20	8,5	14,5	4	250	600	600